

इंटरनेट

मानक

Disclosure to Promote the Right To Information

Whereas the Parliament of India has set out to provide a practical regime of right to information for citizens to secure access to information under the control of public authorities, in order to promote transparency and accountability in the working of every public authority, and whereas the attached publication of the Bureau of Indian Standards is of particular interest to the public, particularly disadvantaged communities and those engaged in the pursuit of education and knowledge, the attached public safety standard is made available to promote the timely dissemination of this information in an accurate manner to the public.

“जानने का अधिकार, जीने का अधिकार”

Mazdoor Kisan Shakti Sangathan

“The Right to Information, The Right to Live”

“पुराने को छोड़ नये के तरफ”

Jawaharlal Nehru

“Step Out From the Old to the New”

IS 1477-1 (1971): Code of Practice for Painting of Ferrous Metals in Buildings, Part 1: Pretreatment [CED 13: Building Construction Practices including Painting, Varnishing and Allied Finishing]

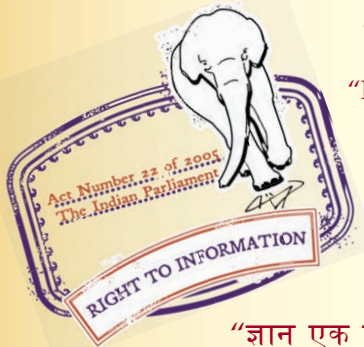

“ज्ञान से एक नये भारत का निर्माण”

Satyanarayan Gangaram Pitroda

“Invent a New India Using Knowledge”



“ज्ञान एक ऐसा खजाना है जो कभी चुराया नहीं जा सकता है”

Bhartrhari—Nitiśatakam

“Knowledge is such a treasure which cannot be stolen”

BLANK PAGE



Indian Standard

CODE OF PRACTICE FOR PAINTING OF FERROUS METALS IN BUILDINGS

PART I PRETREATMENT

(*First Revision*)

UDC 698.12:667-636-221

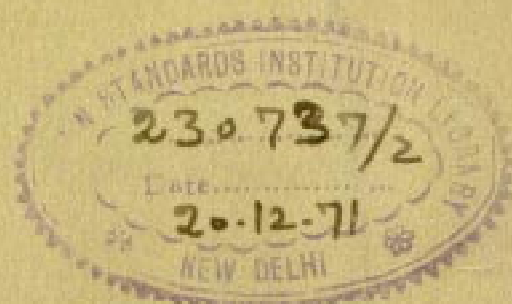
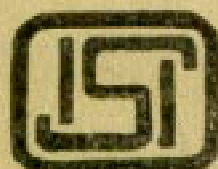

© Copyright 1971

INDIAN STANDARDS INSTITUTION
MANAK BHAVAN, 9 BAHADUR SHAH ZAFAR MARG
NEW DELHI 1

Indian Standard

CODE OF PRACTICE FOR
PAINTING OF FERROUS METALS
IN BUILDINGS

PART I PRETREATMENT

(First Revision)

Painting, Varnishing and Allied Finishes Sectional Committee, BDC 34

<i>Chairman</i>	<i>Representing</i>
SHRI B. SHIRAZI	Cole Paints & Contracts Pvt Ltd, Bombay
<i>Members</i>	
SHRI S. K. ANAND	Engineer-in-Chief's Branch, Army Headquarters
SHRI V. V. SASIDARAN (<i>Alternate</i>)	
SHRI N. S. BHARATIA	Blundell Eomite Paints Ltd, Bombay
SHRI C. J. BHUMKAR	The Indian Paints Association, Calcutta
SHRI T. K. S. MANI (<i>Alternate</i>)	
SHRI S. K. BOSE	National Test House, Calcutta
SHRI K. C. SEAL (<i>Alternate</i>)	
SHRI P. K. CHAKRAVARTI	Directorate General of Supplies & Disposals, New Delhi
SHRI G. S. SAVKAR (<i>Alternate</i>)	
SHRI K. R. CHANDRASHEKHAR	Central Water & Power Commission, New Delhi
SHRI V. J. PATIL (<i>Alternate</i>)	
CHEMIST AND METALLURGIST (RESEARCH, DESIGNS AND STANDARDS ORGANIZATION, CHITTARANJAN)	Ministry of Railways
SHRI B. CHOWDIAH	Ministry of Shipping and Transport
SHRI A. K. DAS GUPTA	Public Works Department, Government of West Bengal
DIRECTOR	Indian Lac Research Institute (CSIR), Ranchi
SHRI SHRAYAN KUMAR (<i>Alternate</i>)	
DR V. M. DOKRAS	Institution of Engineers (India), Calcutta
SHRIMATI S. GURUSWAMY	Curzon & Co, Madras
SHRI HAZARI LAL MARWAH	Central Builders' Association, New Delhi
SHRI K. P. MUKHERJEE	National Metallurgical Laboratory (CSIR), Jamshedpur
SHRI S. V. NATHAN	Goodlas Nerolac Paints Pvt Ltd, Bombay
DR A. V. R. RAO	National Buildings Organization, New Delhi
SHRI O. P. RATRA (<i>Alternate</i>)	

(Continued on page 2)

INDIAN STANDARDS INSTITUTION
MANAK BHAVAN, 9 BAHADUR SHAH ZAFAR MARG
NEW DELHI 1

IS: 1477 (Part I) - 1971

(Continued from page 1)

Members

SHRI B. S. RAWAT
SHRI P. B. SHAH
SHRI S. M. SINGH

DR R. K. SUD
SUPERINTENDING SURVEYOR OF
WORKS (SOUTH WESTERN
ZONE), BOMBAY
SURVEYOR OF WORKS I AT-
TACHED TO THE OFFICE OF
SSW (NEW DELHI ZONE),
NEW DELHI (*Alternate*)

SHRI Y. S. SWAMY

SHRI D. AJITHA SIMHA,
Director (Civ Engg)

Representing

Forest Research Institute and Colleges, Dehra Dun
Asian Paints Co (India) Pvt Ltd, Bombay
Central Building Research Institute (CSIR),
Roorkee

Nagrath Paints Pvt Ltd, Kanpur
Central Public Works Department, New Delhi

Imperial Chemical Industries (India) Pvt Ltd,
Calcutta
Director General, ISI (*Ex-officio Member*)

Secretary

SHRI L. RAMACHANDRA RAO
Deputy Director (Civ Engg), ISI

Indian Standard

CODE OF PRACTICE FOR PAINTING OF FERROUS METALS IN BUILDINGS

PART I PRETREATMENT

(First Revision)

0. FOREWORD

0.1 This Indian Standard (Part I) (First Revision) was adopted by the Indian Standards Institution on 26 March 1971, after the draft finalized by the Painting, Varnishing and Allied Finishes Sectional Committee had been approved by the Civil Engineering Division Council.

0.2 The Part I covers the details of pretreatment to be provided at factory and/or at site to the ferrous metals before they are actually painted and the Part II covers details of painting and paint schedules for ferrous surfaces. These two parts are intended to give guidance for obtaining good protection to ferrous surfaces by painting under general atmospheric conditions.

0.3 This Standard (Part I) is now being revised taking into account the experience gained in this field during the past decade. The salient features of the revision of this part are as follows:

- a) Pretreatment to be provided to the ferrous metals at factory and/or at site are covered in greater detail, and
- b) Details of sand-blasting are covered.

0.4 In the formulation of this standard due weightage has been given to international co-ordination among the standards and practices prevailing in different countries in addition to relating it to the practices in the field in this country.

0.5 For the purpose of deciding whether a particular requirement of this standard is complied with, the final value, observed or calculated, expressing the result of a test or analysis, shall be rounded off in accordance with IS: 2-1960*. The number of significant places retained in the rounded off value should be the same as that of the specified value in this standard.

*Rules for rounding off numerical values (*revised*).

1. SCOPE

1.1 This standard (Part I) covers in detail the pretreatment to be provided to ferrous surfaces in buildings before painting under general atmospheric conditions.

2. TERMINOLOGY

2.0 For the purpose of this standard, the definitions of terms given in IS: 1303-1963* in addition to those in **2.1** and **2.2** shall apply.

2.1 White Metal (with Reference to Sand-Blasting Operations)— A surface with grey white, uniform metallic colour, slightly roughened to form a suitable anchor pattern for coatings. The surface, when viewed without magnification, shall be free of visible mill scale, rust, corrosion, oxides, paint or other foreign matter.

2.2 Shadow— Shadows on the metal surface with reference to sand-blasting operations caused by the incomplete removal of the grey binder between the mill scale and the steel, but having no particular detrimental effect.

3. NECESSARY INFORMATION

3.1 For efficient planning and execution, detailed data and information as given below shall be taken into account while painting ferrous metals:

- a) The condition of the metal surface and the presence of harmful materials on it (scale, rust, moisture, greasy dirt, salts, etc);
- b) Environments in which the paint coating will have to function; and
- c) Information on the nature of previous finish is desirable for repainting during maintenance.

4. DESIGN CONSIDERATIONS

4.1 The surfaces to be painted should be accessible, suitable for priming and affording maximum protection throughout the life of the paint.

4.1.1 Metal surfaces should be either painted and butted together or kept sufficiently far from each other or from a wall to permit painting. This particularly applies to back-to-back angle irons in trusses.

4.1.2 Contact faces of metal should be suitably welded, brazed or adequately bedded with suitable gap-filling jointing compound. Buried or hidden faces should be protected from corrosion by priming and applying a further coat of protective paint. Sharp edges shall be slightly rounded to avoid paint receding from them.

*Glossary of terms relating to paints (*revised*).

4.1.3 Suitable arrangements shall be made for proper drainage to prevent collection of rain water which would cause rusting of ferrous surfaces.

5. SURFACE PREPARATION AND PRETREATMENT

5.1 Pretreatment and priming of ferrous metals under controlled conditions of the factory gives the best results and it is therefore advisable to adopt this method whenever possible. The object of such treatment is to preserve and maintain the metal surface during transport, storage and erection and to minimize the 'on site' preparation for final painting. Much will depend upon the time between the factory treatment and erection, the care with which the materials have been stored and handled during that period, and the protective quality of the treatment applied.

5.1.1 Application of a suitable priming coat should follow pretreatment without delay. Subsequent coats of paint may be applied on the site after cleaning down any damaged parts and touching up with the primer paint.

6. FACTORY PRETREATMENT

6.1 Removal of Oil, Grease, Dirt and Swarf—Generally, the application of any coating, lining material, adhesive or paint, requires as its first essential a perfectly clean surface which is of very great importance while dealing with the painting of ferrous metals. Steel is normally supplied covered with oil and grease either as a protective layer to prevent corrosion or as a left-over from machining and handling. The customary procedure of applying a so-called 'shop coat' of paint after fabrication which consists of wiping the surface with oily cotton waste left-over from other operations, defeats the purpose of painting at the start. Any paint coat applied on greasy or oily steel surfaces will lack proper adhesion and will lead to the failure of the paint film. It is, therefore, essential that even the minute traces of grease and oil are removed prior to the application of any paint. Grease removal shall be carried out either with solvent-type or alkali-type degreasing agents. The material used is not so important as the final result which shall be a thoroughly clean surface without any oil, grease or alkali left-over.

6.1.1 Solvent Cleaning—There are numerous proprietary brands of solvent, alkaline and emulsion cleaners available; where these are used the manufacturer's instructions should be followed.

6.1.1.1 Petroleum-solvent cleaning—These methods relate to the use of petroleum solvents, such as kerosene and mineral turpentine (white spirit) for the removal of oil, grease, dirt and swarf from unit parts or simple assemblies having easily accessible surfaces. Petroleum solvents may also be applied to the 'in situ' cleaning of large units, assemblies or machinery which cannot be accommodated in degreasing equipment. Petroleum

solvent should not be used for assemblies containing fabric, rubber, or other non-metallic materials, unless it is known that no harm will result. The petroleum solvent cleaning shall be carried out in accordance with the detailed procedure given in IS:6005-1970*. The following precautions should be taken during petroleum solvent cleaning process:

- a) *Handling precautions* — Articles should be placed on hooks or racks or in suitable containers that permit adequate draining. They should not be handled with bare hands after cleaning; clean gloves or similar protection should be used and handling kept to a minimum.
- b) *Safety precautions* — Petroleum solvents should be used at room temperature and suitable exhausts and fire extinguishers should be provided, as these solvents are flammable. Oil-resisting synthetic rubber gloves should be worn when handling articles during cleaning, to protect the articles from sweat residues and to avoid any possible effect of the solvent on the skin. Care should be taken to avoid breathing the petroleum solvent vapour.

6.1.1.2 Trichloroethylene cleaning — This method relates to surface cleaning with the trichloroethylene solvent. Trichloroethylene degreasing should not be used on assemblies containing fabric, rubber or other non-metallic materials unless it is known that no harm will result. The procedure to be followed shall be in accordance with the details given in IS:6005-1970*. The following precautions should be taken during trichloroethylene cleaning process:

- a) *Handling precautions* — During processing, the articles should be placed on hooks or racks or in a suitable container. They should be so arranged that there is adequate opportunity for the solvent to drain from holes, crevices and other irregularities. After cleaning, articles should not be handled with bare hands; clean gloves or similar protection should be used.
- b) *Safety precautions* — Trichloroethylene is a toxic substance and therefore, care should be taken to avoid breathing the vapour near degreasing equipment. Trichloroethylene is non-inflammable, but flames may cause decomposition of the solvent vapour with the production of harmful acidic gases; therefore, they should not be allowed near degreasing equipment.

6.1.2 Alkaline Cleaning — Alkaline solutions are good degreasing agents but as they are usually injurious to the skin, they should not be used except in process tanks. The exception is trisodium phosphate, a very mild alkali which is a good cleaning medium. This material may be used for

*Code of practice for phosphating of iron and steel.

degreasing at site as well as in the workshop. Caution is necessary and thorough rinsing shall be ensured when porous articles or parts and assemblies that tend to trap the solution are cleaned in alkaline cleaners. The two methods of alkaline cleaning, namely, the immersion and the spray-degreasing process shall be carried out in accordance with the detailed procedure given in IS:6005-1970*. Immersion cleaning is the commonly used method of degreasing. Spray treatment may be adopted where the volume of production is high or the surface contamination is predominant.

6.1.3 Emulsion Cleaning— These are either single or diphasic cleaners of oil-water emulsion type. They contain very little alkali but rely on powerful emulsifying agents and hydrocarbons to remove grease. While they cannot be compared to heavy-duty cleaners based on caustic soda, they are very satisfactory for most cleaning jobs. Emulsion cleaning is particularly preferred before phosphating as it subsequently leaves a fine-textured phosphate coating. Besides, its operating temperature is generally lower than that of heavy-duty alkaline cleaners. Emulsion cleaners may be applied both by spray and dip, though the former is more common.

Emulsion cleaners should be correctly formulated, otherwise emulsion stability will pose problems. There are several proprietary products and manufacturer's instructions should be followed for their operation to get best results.

6.1.3.1 Equipment— Emulsion cleaners may be used in simple mild steel tanks for dip applications or mechanized power-spray plants for spray application.

• **6.1.4 Other Methods of Cleaning**— There are other methods of cleaning, such as electrolytic cleaning and steam cleaning. These methods are seldom used for cleaning of ferrous metals in buildings. For details of procedure for carrying out these processes, IS:6005-1970* may be referred.

• **6.1.5 Prevention of Contamination**— After degreasing has been completed, if no derusting or descaling is required, the selected paint coat shall be applied immediately, preferably without touching the surface with bare hands which may be slightly greasy even when quite clean. This may not always be possible; nevertheless, care shall be taken to prevent the surface from getting recontaminated.

• **6.2 Removal of Rust and Scale**— When steel leaves the rolling mill, it has a firmly-adhering skin known as 'mill scale'. The continuous fresh layer of mill scale is in itself a good protection against corrosion of the underlying steel. However, on exposure to the atmosphere, mill scale

*Code of practice for phosphating of iron and steel.

absorbs moisture and commences to work itself loose allowing moisture to penetrate between the scale and the steel and resulting in rust formation. Old steel, which has been kept for a long time in the open, has heavy layers of rust formed on its surface. If paint is applied on the layers of rust or loose mill scale, rusting continues almost to the same extent as if there was no paint, with the added disadvantage that over heavy layers of paint progressive corrosion is not easily detected. Derusting and descaling are the essential preparations required prior to the application of any type of coating on iron and steel. There is considerable difference between the condition of a new steel which requires painting and old steel which has been allowed to weather and rust, and the approach to each problem is different. Generally, derusting and descaling of steel may be carried out either mechanically or chemically.

6.2.1 Mechanical Cleaning—This may be done by scraping, chipping, wire-brushing, rubbing with abrasive paper or steel wool, by flame cleaning and sand- or shot-blasting. New steel that is to be painted has normally a surface partly rusted and partly comprising of firmly adhering mill scale. Once the firmly-adhering mill scale has broken, it is extremely difficult to determine whether the remaining mill scale is adhering firmly enough to be left on the surface or should be removed. For ordinary working conditions, it is practically impossible to remove firmly-adhering mill scale by any hand operation. Any specification, which requires the cleaning or removing of mill scale or rust by 'scraping', sand-papering, chipping, wire-brushing, etc, shall, therefore, be understood to mean that firmly adhering mill scale will not be removed and that the surface finally obtained will not give optimum protection against rust at a later date. While this refers to reasonably new steel which has been protected against excessive weathering in a yard or workshop, quite often very old steel is used on construction or in manufacturing processes where heavy rust or scale has formed. This type of scale consists of numerous layers of rust or chemically broken down steel and is not the same as the thin layer of mill scale. The difference is obvious in appearance; while mill scale is bluish-black in colour, rust scale is rusty-brown in colour. Such rust and scale can usually be removed completely with a scraper or a chipping hammer or both. If complete removal of all types of mill scale is required (which is the best preparation) the only really efficient mechanical method of doing this is by sand-blasting or shot-blasting (*see Appendix A*).

6.2.1.1 Hand-scraping—The correct procedure shall be to scrape thoroughly with a hand scraper followed by wire-brushing (first with coarse and then with fine wire-brushes), and finally sand-papering the surface with coarse sand paper (No. 3) steelwood (No. 2) or emery paper (No. 3) or emery cloth. This will give a reasonable assurance that no loose mill scale or heavy rust is left on the surface. For purpose of examination, the hand cleaned surface shall be wiped finally with mineral turpentine, which also removes grease and perspiration left by handmarks.

6.2.1.2 Scraping with mechanical power tools—Appreciably better results than by hand scraping may be obtained by employing power-operated wire-brushes, although it may not be possible to remove firmly-adhering mill scale even with this type of tool. The use of chipping hammers is restricted only to old rust.

6.2.3 Flame Cleaning—Flame cleaning is carried out with the help of a special oxy-acetylene torch. The mill scale is rapidly heated while the underlying steel remains comparatively cold. Because of the difference in expansion between the heated mill scale and the bulk of the steel, the scale will become loose and will either fall off or be easily removed with a wire-brush. As only heating of the scale without heating of the steel itself will ensure complete removal of any firmly-adhering mill scale, it is obvious that this work requires considerable skill and is, therefore, limited to carefully trained labour. While flame cleaning is restricted to heavy steel, as it may lead to buckling of light gauge material, it shall always be ensured that the number of passes the oxy-acetylene flame makes over a surface does not exceed 3. The primer coat of paint shall be applied immediately after the flame cleaning has been carried out when the surface is still warm. This alone will assure the absence of any moisture on the metal surface and, therefore, a perfect adhesion of the paint to the steel. Any minor scale, which correct flame cleaning has not removed after wire-brushing, may be left in position as the potential corrosive effect of this residual scale is nullified by its having been completely dehydrated.

6.2.3.1 Flame cleaning is not suitable for use in confined spaces where there is a fire risk, or where inflammable materials adjoin the surfaces being cleaned.

6.2.4 Sand-Blasting and Shot-Blasting—The process of sand-blasting or shot-blasting is the most thorough system of cleaning steel. The principle is to imping under pressure of air, a jet of sharp sand or granulated steel (steel grit) on to the metal surface, removing in the process any rust and scale, including firmly-adhering mill scale. A steel surface properly cleaned by sand-blasting may be immediately recognized by its silver-grey surface and the criterion for good sand-blasting or shot-blasting is the even colour of the surface so cleaned. An air compressor with a displacement of 4.5 m³ will suffice for the work, but a compressor giving about 5.5 m³ of air would give faster results. Details of sand-blasting and shot-blasting equipment, hoppers, hoses, attachments, etc, are given in Appendix A. Many of these are either readily available or may be built locally. Sand-blasting is injurious to the labour carrying out this work. Suitable spray masks shall, therefore, be worn by workmen to prevent them from inhaling silica sand dust, which may lead to silicosis. River sands which are hard and sharp are most suitable for sand-blasting. The criterion shall be that the sand is free from loam and mud, and is sharp and hard. The high

cost of steel shot restricts its application to a shop where shot-blasting or sand-blasting cabinets can be used. The cost of sand-blasting is approximately equivalent to the cost of a first class 4-coat paint job but this extra expense is fully justified as with a reasonable cycle of repainting the finishing coat only, it will not be necessary to clean the steel to bare metal at a subsequent date, and the protection against corrosion will be optimum. Precautions shall be taken when sand- or shot-blasting light gauge steel to see that buckling does not occur as a result of continuous impingement of sand or steel shots under high velocity.

6.2.4.1 In areas, where presence of inflammable vapours is a possibility, such as near petrol tanks in oil terminals or refineries, special non-sparking wire-brushes, chipping hammers and scrapers shall be used. Precautions with regard to sand-blasting operations in inflammable areas shall be observed in accordance with Appendix B.

6.2.5 *Chemical Cleaning (Pickling)*

6.2.5.1 *Sulphuric-, hydrochloric- or phosphoric-acid pickling*—Where descaling is required to be done chemically, pickling in any of the above acids is necessary. It also removes rust. Pickling shall be carried out in accordance with the detailed procedure given in IS:6005-1970*.

6.2.5.2 After chemical cleaning in any of the acids given in **6.2.5.1**, the articles shall be thoroughly washed to remove all traces of acid. This shall be done in 2 or 3 successive water immersion baths or by water-power jets. The washing may also be carried out by alternate use of immersion bath and water-power jets. After removal of the pickled steel from the washing bath, a fine layer of rust (oxide) will immediately form. This may be prevented by dipping the steel into a 1 to 2 percent phosphoric acid solution which should be carefully rinsed off with clean water. A phosphoric acid wash shall not be used, however, if the articles are subsequently to be phosphated for rust-proofing and paint-bonding, and the phosphate wash should not be considered as a substitute for this.

6.2.5.3 Derusting in acids shall be handled with care in order to prevent excessive attack on as well as embrittlement of the metal. There are a number of proprietary products which prevent attack on steel by acid as well as metal embrittlement and the use of these products (known as 'Inhibitors'), is recommended.

6.2.6 *Other Derusting Systems*—Just as in the case of degreasing, there are numerous other systems for the chemical and mechanical removal of rust, or scale. They include cleaning with tumbling barrels, polishing machines, etc.

*Code of practice for phosphating of iron and steel.

6.3 Phosphate Treatment—The most widely used pretreatments for good adhesion of paint to metal surfaces as well as for the prevention of rust, are the numerous hot-tank phosphating processes. These are most popularly known under such trade names as 'Granodizing', 'Bonderizing', 'Walterizing', etc. There are similar processes of cold application which are suitable for work at site, but they are not so effective as the hot-bath processes which are restricted to shop work. The phosphate treatment to ferrous surfaces shall be provided in accordance with IS:6005-1970*.

6.4 Intermediate Protective Treatments—After the preparation of ferrous surfaces and prior to the application of the protective and decorative paint finishes, a number of intermediate treatments such as red oxide primer or zinc rich primer may be adopted to give ferrous surfaces additional protection against corrosion.

6.5 Non-aqueous Phosphate Coatings—These are generally phosphate coatings which form a self-sealing iron phosphate coating on the surface. These may be applied on a clean dry surface by brush, dip or spray both at factory and/or at site.

6.6 Etching or Wash Primers—This treatment is based on the deposition of an acid-bound resinous film on the ferrous surface in such a manner as to enhance the adhesion of subsequently applied paint coatings. The primer may be applied by brush, spray or dip. The film has good adhesion to the metal substrate.

7. ON-SITE PRETREATMENT

7.1 Surfaces Untreated or Protected with a Temporary Protective—These should be dealt with, at site, as given in 7.1.1 to 7.1.4.

7.1.1 Temporary protective materials applied to steel sheets to protect during storage, transport and erection should be removed with suitable solvent as a preliminary to other preparatory treatments.

7.1.2 Lubricants used in the rolling of steel sheets may be particularly tenacious and may have undesirable effects on paint adhesion. The use of abrasive paper watted with suitable solvent, is effective in removing the worst effects of these materials. Where joints are welded, soldered or brazed care should be taken to remove fluxing material before painting. This may be effected with a 10 percent aqueous solution of formic acid followed by thorough washing, or with suitable solvents.

7.1.3 In the case of heat hardened alloys the surface shall be treated by mechanical roughening combined by degreasing. Such work should be carried out as thoroughly as possible to ensure that the paint will adhere

*Code of practice for phosphating of iron and steel.

IS:1477 (Part I) - 1971

well and give protection and durability. The surface should be well scraped or swabbed with a suitable solvent, and then abraded with abrasive paper and finally rinsed with successive portions of clean solvent on clean swabs.

7.1.4 Proprietary compositions may be used as recommended by the manufacturers to degrease and passivate or degrease and etch the surface, but care should be taken, unless the manufacturers specify otherwise, to remove all residues by wiping or washing where possible, before painting and also to ensure that the compositions do not contaminate other parts of the structure.

7.2 Surfaces Containing Temporary Protective; Scale, Rust, etc — Such surfaces should be dealt with, at site, as given in 7.2.1.

7.2.1 Temporary rust protectives will be removed as detailed in 8.1. Descaling may be done by mechanical methods such as hand-scraping or shot-blasting or flame cleaning as suited to the job at site (for details, see 6.2.1). Where only derusting is to be done this may be done by a mechanical method or chemical method. Proprietary derusting compositions both in liquid and paste form are available for use at site and they may be used following the manufacturer's instructions.

7.3 Surfaces Already Factory Pretreated and/or Primed — They should be carefully inspected and damaged areas should be thoroughly degreased by clean solvent swabbing, any corrosion products formed should be thoroughly removed and touched up with a coat of wash or etching primer on suitable chemical pretreatment solutions. The rectified areas should then be brought forward with appropriate primer, putty, finish coats, etc.

7.4 Solvent Cleaning — This shall be done in accordance with 6.1.1.

7.5 Brush Derusting With Phosphoric Acid or Proprietary Products — Apply phosphoric acid with a brush or swab, rubbing where necessary with a steel wool pad, to assist rust removal. Keep the surface well wetted with the phosphoric acid. Wash off the phosphoric acid thoroughly after derusting paying particular attention to seams and crevices. Proprietary products are used following the manufacturers' instructions.

7.6 Mechanical Cleaning — This shall be carried out in accordance with 6.2.1.

7.7 Etching or Wash Primers — This shall be done in accordance with 6.6.

7.8 Phosphating — Proprietary products, both aqueous and non-aqueous for phosphating 'in situ' may be used following the manufacturers' instructions.

8. PICTORIAL SURFACE PREPARATION STANDARDS FOR PAINTING STEEL SURFACES

8.1 The effective life of the paint coating applied to a steel surface is to a very large extent dependent on how thoroughly the surface has been prepared prior to painting. It is also important to specify clearly the quality of preparation required in each particular case. Accordingly, four grades of rusting and a number of preparation grades, each establishing a quality grade of preparation prior to protective painting, required on a steel surface in a stated rust grade*, have been specified.

9. IMPORTANCE OF EARLY APPLICATION OF PAINTS

9.1 After completion of the precleaning, the ferrous surfaces shall be immediately painted unless a rust-proofing or other interim process is employed. In the latter case, the precleaning shall be followed immediately by that process. If, for instance, a sand-blasted piece of steel is left exposed in a coastal area for only 12 hours, slight rust formation would be visible and the iron oxide thus formed would readily absorb moisture from the humid atmosphere. Sand-blasted steel left exposed for any length of time would thus have to be retreated. In chemical cleaning, after removal of excess acids by thorough washing, the articles shall be immediately dried and painted. Correct timing is essential in all processes of preparation, when painting ferrous surfaces.

A P P E N D I X A

(*Clauses 6.2.1 and 6.2.4*)

SAND-BLASTING

A-1. GENERAL

A-1.1 Sand-Blasting — Sand-blasting produces an excellent surface for painting, and though, it may be initially more expensive than other

*The standardized rust and preparation grades, are defined and presented in colour prints representing a full scale view of part of a surface in the SVENSK Standard SIS 055900-1967 'Pictorial surface preparation standards for painting steel surfaces' published by the Swedish Standards Institution.

methods, it is very economical over a period of years. As with any other method, it can be performed to varying degrees of completion as described in **A-1.2**, **A-1.3** and **A-1.4**.

A-1.2 Blast Cleaning to White Metal—This gives a light grey steel surface of uniform appearance with complete removal of all corrosion products, mill scale, paint, etc. In this method, the abrasives are propelled through nozzles on to the surface. In general, it may be stated that, in this process, the sand-blasting shall be complete but it is not necessary to produce a surface so uniformly blasted as to be free of all shadows.

A-1.3 Commercial Blast Cleaning—Commercial surface finish shall be free of visible mill scale, rust, corrosion oxides, paint or other foreign matter, but may not be free of 'shadows'. It may be produced at the rate of 15 to 25 m²/nozzle hour using a 8-mm nozzle at 7 kgf/cm² pressure held approximately 450 mm from the surface. The actual rate of blasting to obtain a commercial finish is variable and is mainly dependent upon surface conditions (amount and degree of adhesion of mill scale, rust scale, etc) and the type of surface (flat, curved, regular, irregular, etc).

A-1.4 Brush Off Blast Cleaning—This is a relatively low-cost method of cleaning as compared to **A-1.2** and is nearly the same as 'commercial blast cleaning' except that the rate of application is so high that only a limited amount of mill scale and rust are removed. It is generally intended to supplant hand cleaning and power-tool cleaning methods where facilities are available for blast cleaning. The remaining mill scale, rust and paint shall be tight and the surface sufficiently abraded to provide satisfactory adhesion and bonding of paint. The rate of cleaning for a plain or slightly curved surface is about 45 to 65 m²/nozzle hour.

A-2. WORKING PRINCIPLE OF SAND-BLASTING EQUIPMENT

A-2.1 Direct Pressure Sand-Blasting (Intermittent Type) (see **Fig.1 A**)—The pressure is supplied from a compressed air-pressure tank. The abrasive is stored in a pressure storage container in the form of a hopper; the air pressure is maintained on the surface of the abrasive so that it flows from the bottom of the hopper through a valve into the mixing chamber, where the compressed air carries it to the nozzle. Each time, the hopper gets empty, the compressed air valve is shut and the hopper recharged after unscrewing the top.

A-2.1.1 The rate of flow of abrasive may be controlled by varying the air pressure. Normally, the best pressure to use in the equipment will be approximately 5 to 6 kgf/cm² with a displacement of 5.6 to 7 m³/min, which gives a 25 to 30 m²/nozzle hour of commercially blasted area.

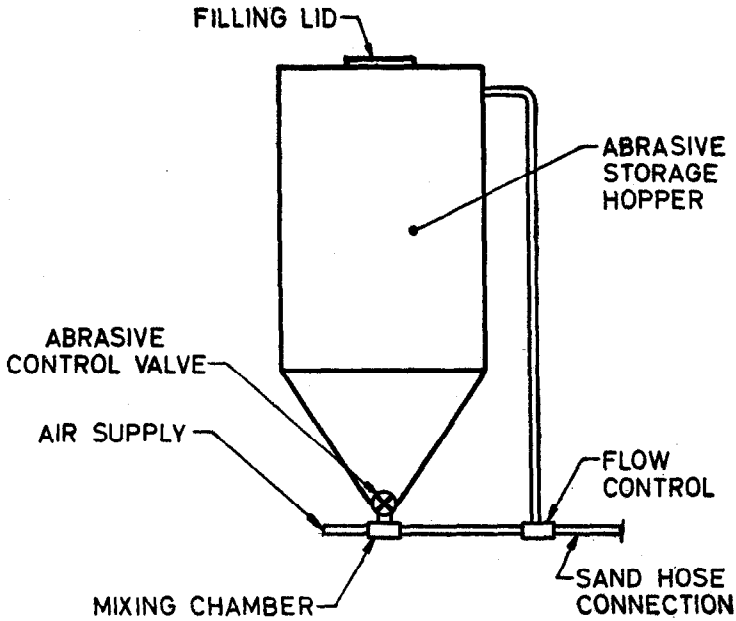

1A INTERMITTENT TYPE

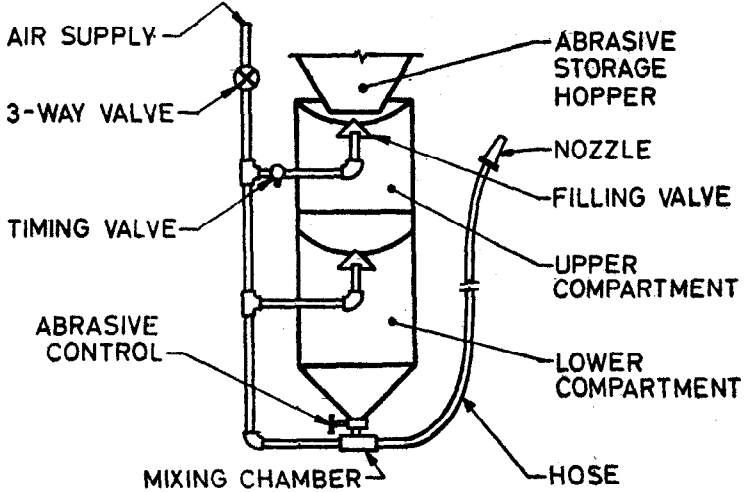

1B CONTINUOUS TYPE

FIG. 1 ESSENTIAL ELEMENTS OF SAND-BLASTING EQUIPMENT

A-2.2 Direct Pressure Sand-Blasting (Continuous Type) (see Fig. 1B)*— This contains two storage compartments for the abrasive. During blasting operation, the abrasive is fed from the lower compartment, and the upper compartment may be filled with abrasive as and when required without disturbing the operation of the lower compartment. When the lower compartment needs filling, pressure is turned on to the upper compartment, which releases the valve between upper and lower compartments and also seals off the upper chamber from the feeding hopper above, and the abrasive feeds into the lower chamber from the upper one. When the air pressure is cut off to the upper chamber, the valve connecting it to the lower chamber is closed and the upper chamber is opened to the hopper at the top for feed of abrasive. The net result of this operation is the maintenance of a continuous supply of abrasive irrespective of the intermittent feedings to the upper chamber, and also an uninterrupted operation.

A-2.3 Suction Feed Type of Blast Equipment— This equipment may be constructed or used for cleaning of welds, or small areas of ferrous surfaces. The equipment operates because of a vacuum which is created by compressed air passing through a small jet in the suction gun into an induction chamber before passing through a larger nozzle. The induction chamber is connected by means of a suitable hose to the source of abrasive. The amount of abrasive that is sucked into the equipment depends upon the vacuum created, the lift required, and the type of abrasive. Because of the limited amount of vacuum that may be created by the jet, the suction lift is decreased. Figure 2 illustrates the principles of operation of this type of equipment. Compressed air passes through the small jet and creates a vacuum. The static pressure in the larger nozzle is about 75 percent of that at the inlet of the smaller nozzle. Secondary air and abrasive are sucked into the feed hose from the inlet end near the hopper. The position of the hose at the hopper is moved forwards or backwards to vary the abrasive pickup until the most satisfactory operating condition is reached. In use, the unit may be operated by connecting to a source of air and dropping the inlet end of the hose into a container of abrasive; sand is usually used in such operations.

A-2.4 Closed Recirculating Blast System— This is similar to direct pressure blasting, but the abrasive is recollected by vacuum immediately after blasting. For this purpose, the blast nozzle is enclosed in a compartmental cup which has a brush seal at the bottom in order to control the abrasive flow and to prevent the escape of abrasive. A second hose from the cup leads recollected abrasive into the separator tank from which the abrasive is fed to the suction side of the blower.

A-2.4.1 This type of blast cleaning may not require safety helmets, goggles and respirators which are necessary in the case of direct pressure sand-blasting.

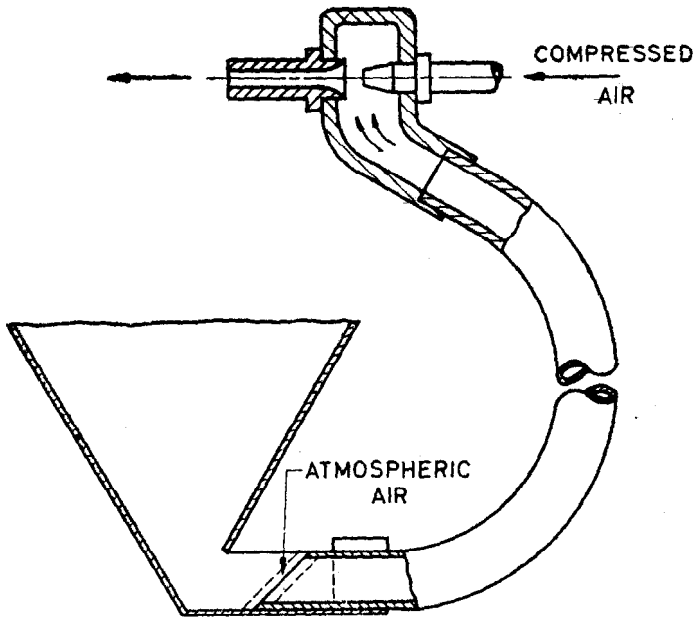
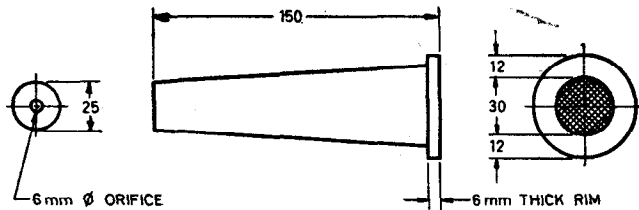

FIG. 2 TYPICAL SUCTION BLAST-CLEANING EQUIPMENT

A-3. NOZZLES

A-3.1 These may be made out of steel pipe or may be fabricated from cast iron. The general shape may be as shown in Fig. 3. The type and size of job govern the size of the nozzle. The nozzle size is usually specified by the internal diameter of the throat. The size shall be selected considering the amount or type of work to be done, the volume of compressed air available, the pressure available, the size of sand or abrasive to be used, etc. Usually, the nozzle length is about 6 times the nozzle size.

A-3.2 Distance of Nozzle from Surface—The nozzle shall be held at the correct distance from the area being blasted and this distance will vary with the type of work being done. The closer the nozzle is held to the surface, the greater the impact of the particle and the more concentrated the blast stream. As the nozzle is moved away from the surface, the blast pattern widens and a greater area is covered. Trial and error will usually indicate the optimum distance at which the nozzle is held from the surface for the particular job and the rate at which it is traversed over the surface to obtain the required degree of surface cleanliness.



All dimensions in millimetres.

FIG. 3 SAND-BLASTING NOZZLE

A-3.3 Angle of the Nozzle with Regard to Surface— The angle of the nozzle to the work is also important. If the nozzle is held perpendicular to the surface, the operation becomes inefficient because of rebounding abrasives slowing down the abrasive emerging from the nozzle. In practice, it is best if the nozzle is held at an angle of approximately 30° to the vertical in order to undercut the material to be removed.

A-3.4 Special Operations with Nozzle— For highly-pitted steel, the nozzle shall be rotated around its own axis in all planes and held at various angles to ensure that the abrasive cleans out all the pores and interstices of the surface being blasted.

A-3.5 In order to prevent blocking of the nozzle by the abrasive, the abrasive used shall generally be not larger than one-third the diameter of the nozzle.

A-3.6 Short nozzles (which are sometimes referred to as button or washer-nozzles) produce a wide spreading of the abrasive in a large blast pattern.

A-3.7 When a number of blast nozzles are operated from one blast tank, the blast hoses shall be of equal diameter and length to equalize the flow of abrasive and to ensure that the sand-blasted surfaces are cleaned to the same degree.

A-4. HOSE

A-4.1 The size of the air-supply line or hose is governed by the amount of air that is flowing and pressure drop that may be tolerated for the length of the hose used.

A-5. ABRASIVES

A-5.1 The types of abrasives that may be used in blasting operations shall be as follows:

- a) Metallic shot, which is approximately spherical in shape obtained from oxyacetylene cutting or other industrial operations;
- b) Siliceous, containing free silica (sand);
- c) Synthetic, non-metallic, containing silica; and
- d) Agricultural (such as nut shells, corn husks, etc).

A-5.2 Use of Metallic Shot — Metallic shots shall not be used on light sections, its use being limited to structural materials that can absorb its impact.

A-5.2.1 Metallic grit is obtained by crushing shot and screening the grit into various sizes. Iron filing or tool-room filings may also be used as abrasives. The advantage of metallic-shot abrasives is that they cut deeper and faster and are efficient for the removal of scale and other hard surface deposits.

A-5.3 Use of Siliceous Abrasives — These may consist of garnet, quartz, silica or decomposed rock. The most widely-used abrasive in field operations is silica sand of maximum particle size not larger than 1.00 mm IS Sieve (see IS: 460-1962*).

A-5.3.1 Loss of abrasive adds considerably to the cost of operation. Periodic analysis or examination of the abrasive in use indicates a distribution of abrasive particles down to the smaller sizes. If these smaller sizes are absent it is an indication that the abrasive is being wasted. In field operations, the sand should be swept up, screened and re-used, if the break down rate is small.

A-5.4 Use of Synthetic Abrasives — These are costlier than sand and, therefore, should preferably be re-used more often than sand. Care shall, however, be exercised to check about the presence of dust. The commonly used synthetic abrasives are refractory slag, aluminium oxide and silicon carbide.

A-5.5 Use of Agricultural Abrasives — These are not expensive, since they are usually waste products. The most common abrasives are hardwood particles, nut shells, coconut shells, etc. These abrasives may be used in cleaning grease, oil, or carbon from finished parts and assembled equipment. The absorbing capacity of the particles gives an effect similar to wiping.

*Specification for test sieves (revised).

A-5.6 Appearance of Surface in Relation to Abrasives Used — Colour is not always a criterion for cleanliness. When using sand, the blast-cleaned surface may appear very white and look very clean. There are two reasons for this, that is:

- a) the fine sand leaves many facets which reflect light, and
- b) a deposit of white silica may add to the white appearance.

When using dark abrasives, the surface may have a dark appearance. It is, therefore, very essential to blow off the surface blasted with dry compressed air prior to priming the same with paint or any other material.

A-6. USE OF SEPARATORS

A-6.1 Separators may be used to remove oil, water, etc, from the compressed air supply. These may be installed either at the end of the connector, (connected to the compressed air tank) or at the bottom of the steel hopper.

NOTE — The separator usually consists of rubber or steel baffles with holes drilled through the plates, and has a water draw-off at the bottom.

A-6.2 For bleeding, there shall be a carefully filtered supply of cool air, which is done generally by means of a separate auxiliary air compressor of a small size. If the compressed air of the plant itself is to be supplied for bleeding purposes, extreme filtration to remove oil and water is necessary. Water usually condenses in the line, and it is important that the compressor lines be properly installed with drip legs to remove water which condenses in the line. The final separator shall be installed adjacent to the blasting stations to remove the last traces of water.

A-7. GENERAL PRECAUTIONS

A-7.1 Suitable equipment for protection from dust shall be provided to those engaged in blast-cleaning operations.

NOTE — Blast-cleaning operations will give rise to a large amount of dust; in exterior work, if done in the direction of wind, the undersized particles are carried away with the air-stream.

A safety type of helmet with a force-feed air supply is a suitable protective equipment. Filter-type air respiration shall be worn by all others who are not actually engaged in the blast-cleaning operations but are exposed to blast-dust environment. Also safety goggles shall be worn by persons near the blasting operations.

Generally in blast-cleaning operations, there is no hazard from silicosis provided the normal safety precautions are taken.

A-7.2 Proper precautions shall be taken against fire explosion hazards before starting the work.

A-7.3 Care shall be taken to protect adjacent machinery, electrical equipment, etc. Shielding by wrapping with waterproof paper and hession cloth may be normally sufficient.

APPENDIX B

(Clause 6.2.4.1)

PRECAUTIONS AGAINST EFFECTS OF STATIC ELECTRICITY IN SAND-BLASTING WORK IN INFLAMMABLE AREAS

B-1. GENERAL

B-1.1 The air and abrasive which pass through the hose create a static charge and, therefore, while doing sand-blasting work in inflammable areas, such as tank farms in oil terminals or on the exterior of tanks full of petroleum products, the nozzle and hose shall be grounded by separate ground wires. All metal parts, between which sparking is liable to occur, shall be bounded with electric conductors to one another and also grounded to earth. Effective bonding shall be done between the tank and sand-blast nozzles, sand hopper and, preferably, the air compressor also. The bonding between the tank, sand-blast nozzle and sand hopper is most important, as it is almost certain that, without bonding, sparking will occur between the tank and sand-blast nozzle.

NOTE — Silica sand will not generally spark under the pressure of 0.6 kgf/cm² but static electricity may be produced at the point of impact between the nozzle and the steel plate of the tank. It is found that the sparks, which are created at the end of the sand-blasting nozzle, are due to static electricity and not due to the impact of the sand on the steel; no high temperature is developed unlike, for instance, sparking at a high-speed grinder.

B-1.2 The bonding conductor shall not be less than 1.5 mm diameter (*see* Note below) and shall be in continuous length. The electrical conductor shall be firmly connected to the sand-blast cable, preferably by means of a clamp. The copper-bonding wire shall be looped to the sand hopper and the air compressor before being terminated on the storage tank, care being taken to see that all connections made are electrically sound.

NOTE — The 16 SWG single strand copper cable (1.6 mm diameter) will be found suitable as bonding conductor.

B-1.3 From the sand hopper to the sand-blast nozzle, the bonding cable shall be clamped to the hose that feeds the nozzle at about 1.5 m intervals, and care shall be taken to see that the cable is not damaged during the operation. If armoured hose is used, the wire armouring shall also be bonded to the sand-blast nozzle.

B-2. WORK AT THE ROOF OF A TANK

B-2.1 When carrying out sand-blasting on the roof of a petroleum storage tank, all openings leading to the inside of the tank shall be covered in such a way as to prevent the entry of sand, but at the same time to permit venting of the product in the tank. For this purpose, a clean muslin cloth may be used to cover the vents.

B-2.2 When sand-blasting at or near a vent, the pressure and vacuum valve or hood shall be removed, and the vent nozzle shall be plugged completely with hession cloth (or a wooden plug in two halves) and made

IS:1477 (Part I)-1971

gas-tight by using clay or stiff grease; alternatively, a blank flange may be used, wherever possible. With this method, product vapours do not escape from the vent and the danger of a fire is eliminated. This shall be done only for one vent at a time, keeping the others fully operating during this phase.

B-2.3 Sand-blasting of the entire roof shall be carried out only during the early morning or late evening hours, when tank breathing is the least. Immediately after this operation each day, all the vents shall be made completely free of covers or plugs mentioned above.

B-2.4 The roofs of floating-roof tanks containing petroleum shall not be sand-blasted; conventional methods of scraping, chipping and painting shall be followed.

B-3. WORK IN RELATION TO WIND DIRECTION

B-3.1 When carrying out sand-blasting on the sides or roof of a tank, the work shall always be done in such a manner with respect to the wind direction that the sand particles are blown away clear of the tank; when sand-blasting the roof, the vents upstream and downstream (with respect to wind direction) of the area being sand-blasted shall be plugged or covered or blank-flanged, the downstream one to prevent product contamination with sand and the upstream one to prevent product vapours from being blown over the area being sand-blasted.

B-4. SUSPENSION OF SAND-BLASTING

B-4.1 All sand-blasting operations for the tank shall be completely suspended when the tank is receiving cargo or when the water bottom is being raised. This shall include switching off of all concerned electrical and motive equipment, such as air compressors.

B-4.1.1 Sand-blasting operations shall not be permitted for the roof when water or product is drawn out of the tank, because the tank has to breath in, and full venting is required.

B-5. REMOVAL OF FINE PARTICLE DEPOSITS

B-5.1 Due to the static electricity, which is formed as the abrasive passes through the hose, the metal shot gets charged and, even after cutting through the mill scale on the surface, fine particles of shot adhere to the metal due to the static charge which they have picked up. This has a further disadvantage, as it is very difficult to blow these fine particles away especially when they become embedded in the anchor pattern formed by the blasting process. A jeweller's brush with fine brass bristles may be used to brush these out and more dry compressed air passed over the surfaces blasted to ensure that these fine metal deposits are completely removed.