

इंटरनेट

मानक

Disclosure to Promote the Right To Information

Whereas the Parliament of India has set out to provide a practical regime of right to information for citizens to secure access to information under the control of public authorities, in order to promote transparency and accountability in the working of every public authority, and whereas the attached publication of the Bureau of Indian Standards is of particular interest to the public, particularly disadvantaged communities and those engaged in the pursuit of education and knowledge, the attached public safety standard is made available to promote the timely dissemination of this information in an accurate manner to the public.

“जानने का अधिकार, जीने का अधिकार”

Mazdoor Kisan Shakti Sangathan

“The Right to Information, The Right to Live”

“पुराने को छोड़ नये के तरफ”

Jawaharlal Nehru

“Step Out From the Old to the New”

IS 1201 to 1220 (1978): Methods for Testing Tar and Bituminous Materials [PCD 6: Bitumen Tar and their Products]



“ज्ञान से एक नये भारत का निर्माण”

Satyanarayan Gangaram Pitroda

“Invent a New India Using Knowledge”



“ज्ञान एक ऐसा खजाना है जो कभी चुराया नहीं जा सकता है”

Bhartrhari—Nitiśatakam

“Knowledge is such a treasure which cannot be stolen”

BLANK PAGE



IS : 1201 - 1978
to
IS : 1220 - 1978
(Reaffirmed 2004)
Edition 2.1
(1996-11)

Indian Standard
METHODS FOR TESTING
TAR AND BITUMINOUS MATERIALS
(*First Revision*)

(Incorporating Amendment No. 1)

UDC 665.775 : 620.1

© BIS 2007

BUREAU OF INDIAN STANDARDS
MANAK BHAVAN, 9 BAHADUR SHAH ZAFAR MARG
NEW DELHI 110002

Price Group 590

IS : 1201 - 1978
to
IS : 1220 - 1978

Indian Standard
**METHODS FOR TESTING
TAR AND BITUMINOUS MATERIALS**
(First Revision)

Bitumen and Tar Product Sectional Committee, BCDC 2

Chairman

PROF C. G. SWAMINATHAN

Representing

Central Road Research Institute (CSIR), New Delhi

Members

- SHRI Y. C. GOKHALE (*Alternate to*
Prof C. G. Swaminathan)
- SHRI N. A. DE. X. ALPHONSO Hindustan Petroleum Corporation Ltd (Refinery
Division), Bombay
- SHRI S. N. MATHUR (*Alternate*)
- PROF G. M. ANDAVAN Highways & Rural Works Department (PWD),
Tamil Nadu
- SHRI A. K. BHATTACHARYYA National Test House, Calcutta
- DR K. S. BHATTACHARYYA Ministry of Defence (DGI)
- SHRI S. K. GANGULI (*Alternate*)
- CHEMIST & METALLURGIST Ministry of Railways (RDSO)
- ASSISTANT CHEMIST & METALLURGIST
(*Alternate*)
- CHIEF ENGINEER Public Works Department, Punjab
- CHIEF ENGINEER (ROADS) Roads Wing (Ministry of Transport)
- SHRI R. P. SIKKA (*Alternate*)
- SHRI G. C. GOSWAMI Assam Oil Co Ltd, Digboi
- SHRI ISWAR CHANDRA (*Alternate*)
- SHRI A. Y. GUPTA Hindustan Petroleum Corporation Ltd (Marketing
Division), Bombay
- SHRI HIMMAT SINGH Indian Institute of Petroleum (CSIR), Dehra Dun
- SHRI J. S. BAHL (*Alternate*)
- BRIG H. K. KAPOOR Engineer-in-Chief's Branch, Army Headquarters
- SHRI J. K. CHARAN (*Alternate*)
- SHRI D. R. KOHLI Bharat Petroleum Corporation Ltd (Marketing
Division), Bombay
- SHRI R. R. BANDRE (*Alternate*)

(Continued on page 2)

© BIS 2007

BUREAU OF INDIAN STANDARDS

This publication is protected under the *Indian Copyright Act (XIV of 1957)* and reproduction in whole or in part by any means except with written permission of the publisher shall be deemed to be an infringement of copyright under the said Act.

IS : 1201 - 1978

to

IS : 1220 - 1978

(Continued from page 1)

<i>Members</i>	<i>Representing</i>
SHRI T. S. KRISHNAMURTHI	Indian Oil Corporation Ltd (Refinery Division), Bombay
SHRI C. V. RAMAMURTHI (<i>Alternate</i>)	
SHRI S. B. KULKARNI	Indian Oil Corporation Ltd (Marketing Division), Bombay
SHRI MAHABIR PRASAD	Indian Roads Congress
PROF C. G. SWAMINATHAN (<i>Alternate</i>)	
SHRI M. R. MALYA	In personal capacity (<i>C/o Gammon India Ltd, Gammon House, Veer Savarkar Marg, P.B. No. 9129, Prabhadevi, Bombay 400025</i>)
SHRI T. S. NAYER	Ministry of Petroleum
SHRI T. P. SUBRAHMANYAN (<i>Alternate</i>)	
DR A.V. R. RAO	National Buildings Organization
DR R. S. RATRA (<i>Alternate</i>)	
REPRESENTATIVE	Ministry of Defence (R&D)
SHRI T. K. ROY	Shalimar Tar Products (1935) Ltd, Calcutta
SHRI DILIP KR. SEN	Central Fuel Research Institute (CSIR), Dhanbad
SHRI ARUN KANTI CHOUDHURY (<i>Alternate</i>)	
SENIOR SURVEYOR OF WORKS (DAZ)	Central Public Works Department
SURVEYOR OF WORKS (DAZ) (<i>Alternate</i>)	
SHRI S. SUBBLAH	Directorate General of Supplies & Disposals
SHRI S. P. GUPTA (<i>Alternate</i>)	
SHRI N. S. THAYAGARAJAN	Bharat Petroleum Corporation Ltd (Refinery Division), Bombay
SHRI C. H. SAHEBA (<i>Alternate</i>)	
SHRI D. AJITHA SIMHA, Director (Civ Engg)	Director General, ISI (<i>Ex-officio Member</i>)

Secretary

SHRI J. R. MEHTA

Deputy Director (Civ Engg), ISI

Methods of Testing Tar and Bitumen Subcommittee, BCDC 2 : 2

Convener

PROF C. G. SWAMINATHAN Central Road Research Institute (CSIR), New Delhi

Members

PROF G. M. ANDAVAN	Highways & Rural Works Department (PWD), Tamil Nadu
SHRI J. S. BAHL	Indian Institute of Petroleum (CSIR), Dehra Dun
SHRI J. M. NAGPAL (<i>Alternate</i>)	
SHRI A. K. BHATTACHARYYA	National Test House, Calcutta
SHRI K. D. DAS (<i>Alternate</i>)	
SHRI G. C. GOSWAMI	Assam Oil Co Ltd, Digboi
SHRI ISWAR CHANDRA (<i>Alternate</i>)	
SHRI B. B. L. KAPOOR	Bharat Petroleum Corporation Ltd (Refinery Division), Bombay
SHRI C. H. SAHEBA (<i>Alternate</i>)	

(Continued on page 3)

IS : 1201 - 1978
to
IS : 1220 - 1978

(Continued from page 2)

<i>Members</i>	<i>Representing</i>
BRIG H. K. KAPOOR	Engineer-in-Chief's Branch, Army Headquarters
SHRI B. S. MANDALIKA (<i>Alternate</i>)	
SHRI S. B. KULKARNI	Indian Oil Corporation Ltd (Marketing Division), Bombay
SHRI M. R. MALYA	In personal capacity (<i>C/o Gammon India Ltd, Gammon House, Veer Savarkar Marg, P.B. No. 9129, Prabhadevi, Bombay 400025</i>)
SHRI K. P. NAIR	Indian Oil Corporation Ltd (R & D Centre), Faridabad
SHRI G. RAGHAVENDRAN	Madras Refineries Limited, Madras
SHRI T. V. VARGHESE (<i>Alternate</i>)	
SHRI C. V. RAMASWAMY	Hindustan Petroleum Corporation Ltd (Refinery Division), Bombay
SHRI A. Y. GUPTA (<i>Alternate</i>)	
SHRI T. K. ROY	Shalimar Tar Products (1935) Ltd, Calcutta
SUPERINTENDING ENGINEER (ROADS)	Ministry of Transport and Shipping (Roads Wing)

IS : 1201 - 1978
to
IS : 1220 - 1978

CONTENTS

	PAGE
FOREWORD	5
IS : 1201-1978 SAMPLING	7
IS : 1202-1978 DETERMINATION OF SPECIFIC GRAVITY	19
IS : 1203-1978 DETERMINATION OF PENETRATION	25
IS : 1204-1978 DETERMINATION OF RESIDUE OF SPECIFIED PENETRATION	29
IS : 1205-1978 DETERMINATION OF SOFTENING POINT	33
IS : 1206 (PART I)-1978 DETERMINATION OF VISCOSITY : PART I INDUSTRIAL VISCOSITY	39
IS : 1206 (PART II)-1978 DETERMINATION OF VISCOSITY : PART II ABSOLUTE VISCOSITY	47
IS : 1206 (PART III)-1978 DETERMINATION OF VISCOSITY : PART III KINEMATIC VISCOSITY	57
IS : 1207-1978 DETERMINATION OF EQUIVISCIOUS TEMPERATURE (EVT)	65
IS : 1208-1978 DETERMINATION OF DUCTILITY	71
IS : 1209-1978 DETERMINATION OF FLASH POINT AND FIRE POINT	75
IS : 1210-1978 FLOAT TEST	87
IS : 1211-1978 DETERMINATION OF WATER CONTENT (DEAN AND STARK METHOD)	91
IS : 1212-1978 DETERMINATION OF LOSS ON HEATING	97
IS : 1213-1978 DISTILLATION TEST	103
This standard deleted Vide Amendment No. 1	
IS : 1215-1978 DETERMINATION OF MATTER INSOLUBLE IN TOLUENE	121
IS : 1216-1978 DETERMINATION OF SOLUBILITY IN CARBON DISULPHIDE OR TRICHLOROETHYLENE	125
IS : 1217-1978 DETERMINATION OF MINERAL MATTER (ASH)	131
IS : 1218-1978 DETERMINATION OF PHENOLS	133
IS : 1219-1978 DETERMINATION OF NAPHTHALENE	137
IS : 1220-1978 DETERMINATION OF VOLATILE MATTER CONTENT	141
APPENDIX A APPARATUS SCHEDULES	145

Indian Standard
**METHODS FOR TESTING
TAR AND BITUMINOUS MATERIALS**
(First Revision)

0. FOREWORD

0.1 These Indian Standards (First Revision) were adopted by the Indian Standards Institution on 30 June 1978, after the drafts finalized by the Bitumen and Tar Products Sectional Committee had been approved by the Civil Engineering Division Council.

0.2 A series of published Indian Standards cover tar, bitumen and bituminous materials. These standards require, amongst other requirements, detailed testing of each of these products. At one stage, the various methods of tests relating to each product were included in the same standard. Since these specifications were prepared over a period of time, the methods of tests, prescribed for the determination of similar properties varied in procedure and equipment from one standard to another. It was, therefore, felt necessary to prepare a standard compilation of methods of test for tar and bitumen to simplify these test procedures and to prescribe, as far as possible, the same standard equipment for determining similar properties.

0.3 This series of standards on methods of tests was first published in 1958. However, during the course of this period a number of improvements have since been made in carrying out of these methods of tests and accordingly, the compilation of methods of tests is now being revised to bring it up-to-date. Modifications have, in particular, been made to the provisions of repeatability and reproducibility limits specified under each test. Also, under methods of tests for determining the viscosity requirements (IS : 1206) additional methods of tests have been included for the determination of 'absolute' and 'kinematic' viscosity under separate parts. IS : 1214-1978 'Determination of matter insoluble in benzene' has been withdrawn due to toxic nature of benzene. This test is not being conducted nationally/internationally. Instead of this, 'Determination of matter insoluble in toluene' is being conducted for which an Indian Standard IS : 1215-1978 exists.

IS : 1201 - 1978

to

IS : 1220 - 1978

0.4 The Sectional Committee responsible for the preparation of these standards has taken into consideration the views of producers, consumers and technologists and has related the standards to the manufacturing and trade practices followed in the country in this field. Due weightage has also been given to the need for international co-ordination between standards prevailing in different countries of the world. These considerations have led the Sectional Committee to derive assistance from the standards and publications of the following associations and committees:

Standardization of Tar Products Tests Committee, London

Institute of Petroleum, United Kingdom

American Society for Testing Materials, Philadelphia

0.5 While preparing this compilation of methods of tests, simplification in the range and type of thermometers, condensers and receivers used in various tests has been kept in view. Accordingly, the committee hopes that this simplification will help the laboratories to equip themselves with a complete range of apparatus for testing tar and bitumen. As a guide to the laboratories a list of apparatus required for testing tar and bitumen according to these standards has been provided in Appendix A at the end. The thermometers specified in this compilation are identified in terms of designations according to the Institute of Petroleum or American Society for Testing Materials and hence their equivalent IP and ASTM designations are also given in the Appendix. Corresponding equivalent Indian Standard designations covering these thermometers are also indicated. It is, however, important to note that all thermometers used in these tests should bear a conformity certificate from the National Physical Laboratory of India or any other institution authorized by the Government of India to issue such certificates.

0.6 This edition incorporates Amendments issued to various parts, one amendment (Amendment No. 1 November 1996) has been issued through which IS : 1214-1978 has been deleted and changes made in the portions applicable to all standards. Details of these are indicated in each part as well as in the last cover page. Side bar indicates modification of the text as the result of incorporation of these amendments.

0.7 In reporting the result of a test or analysis made in accordance with these standards, if the final value, observed or calculated is to be rounded off, it shall be done in accordance with IS : 2-1960*.

*Rules for rounding off numerical values (*revised*).

Indian Standard
**METHODS FOR TESTING
TAR AND BITUMINOUS MATERIALS:
SAMPLING**
(First Revision)

1. SCOPE

1.1 This standard covers methods of sampling bitumen and bituminous materials, in their liquid, semi-solid or solid states supplied in any of the following forms:

- a) Cans or small containers, drums, barrels and bags;
- b) Solid materials in loose form;
- c) Rail tank wagon and road tank trucks/lorries; and
- d) Bulk storage tanks and other types of bulk storage.

NOTE — The provision of this standard shall be applicable to bitumen emulsions also, subject to modifications given in the relevant standards on emulsions.

2. PURPOSE OF SAMPLING

2.1 From a lot representing a part or the whole of the material offered for inspection, samples are taken for the purpose of securing representative portions for visual and laboratory examination or for preservation for record. The examination may be made to determine:

- a) the average quality of the material in the lot,
- b) the extent of variation in quality in the different portions of the material, and
- c) conformity to the specified requirements.

3. TERMINOLOGY

3.0 For the purpose of this standard the following definitions shall apply.

3.1 Lot — The quantity of material of the same composition offered for inspection at one time. A lot may consist of the whole or a part of the quantity ordered for.

IS : 1201 - 1978

3.1.1 *Formation of Lots*

- a) The lot shall be formed before sampling is undertaken;
- b) The basic principle in forming the lot is that the material in the lot should be as homogeneous as possible with regard to the quality characteristics specified; and
- c) Care shall be taken to see that the material in a single lot comes from the same source/batch of manufacture and as far as possible from raw material of identical origin.

3.2 Top Sample — A top sample is one taken at a level of one-sixth of the depth of the material below the top surface and in the centre of the container.

3.3 Middle Sample — A middle sample is one taken at a level of one-half of the depth of the material below the top surface in the centre of the container.

3.4 Lower Sample — A lower sample is one taken at a level of five-sixths of the depth of material below the top surface in the centre of the container.

NOTE 1 — In the case of horizontal cylindrical tanks and tanks of irregular shape, 'top', 'middle' and 'lower' samples taken at levels corresponding to one-sixth, one-half and five-sixths of the depth of product in the tank are not representative. In such circumstances, samples shall be taken at levels corresponding to one-sixth, one-half, and five-sixths of that volume.

NOTE 2 — In the case of cone-roofed tanks the sample may be drawn from as near the centre as possible.

3.5 Average Sample — A true average or representative sample is such that its composition would be the same as that of any part of the quantity sampled if the whole were mixed to ensure homogeneity. When the contents of the vessel are substantially homogeneous as shown by preliminary examination of top, lower and middle samples and the cross section of the vessel is uniform, an average sample is usually made up by combining equal parts of samples drawn from levels at one-sixth, one-half and five-sixths of the depth of the liquid below the top surface.

3.6 Composite Sample — A composite sample is one taken by combining representative samples of a product from a number of containers, that is, from packages, in proportion to the contents of each of the containers sampled.

3.7 Pipeline Sample — A composite sample taken at the filling point in the delivery end of the pipeline.

3.8 All Level Sample — This is obtained by submerging a closed sampler to a point as near as possible to the draw-off level, then opening the sampler and raising it at a constant rate such that it is nearly, but not quite, full as it emerges from the liquid and has drawn in the sample liquid at all levels.

4. SAMPLING APPARATUS

4.1 Bitumen Sampler — A strong metal vessel of about half litre capacity, the handle of which shall be attached by a means not adversely affected by hot bitumen (*see* Fig. 1).

4.2 Sampling Thief or Tube Method — The sampling thief or tube shall be either of glass or metal, to reach to within 3 mm of the bottom of the vessel and having a capacity of approximately half or one litre. A metal tube suitable for sampling 250 litre drums is illustrated in Fig. 2. The rings shall be soldered to opposite sides of the tube at the upper end for convenience in holding it.

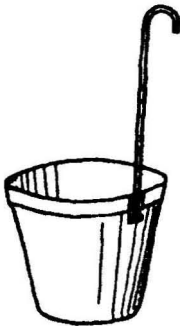
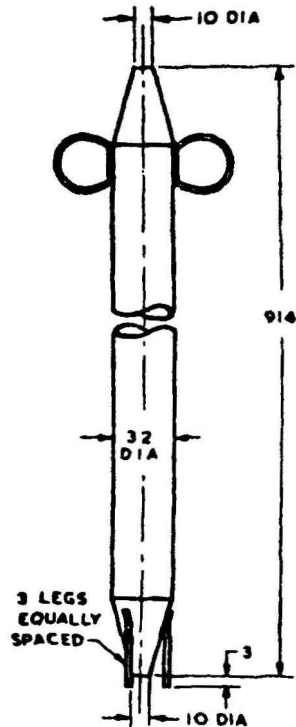

FIG. 1 BITUMEN SAMPLER



All dimensions in millimetres.

FIG. 2 SAMPLING TUBE

IS : 1201 - 1978

4.3 Ship Auger — of such diameter and length as to permit a core of convenient size to be taken throughout the depth of the package or cake as illustrated in Fig. 3.

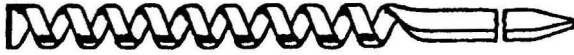

FIG. 3 SHIP AUGER

4.4 Sampling Scoop — of such dimensions as to enable a core of convenient size to be taken throughout the depth of the package (see Fig. 4).

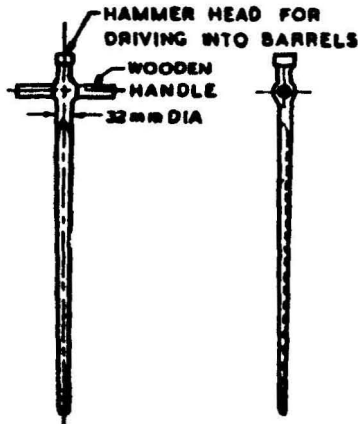

FIG. 4 SAMPLING SCOOP

4.5 Knife or Spatula — provided with a strong, broad steel blade for use with materials which are soft.

4.6 Hammer and Chisel — of any convenient size for use with samples which are hard enough to shatter.

4.7 Bottle Sampler — made of metal with a handle and stopper (see Fig. 5).

5. SAMPLE CONTAINERS

5.1 Containers for the samples of liquid bituminous materials shall be small-mouth cans with cork-lined screw caps, except for emulsions, in which case they shall be wide-mouth glass jars or bottles. Containers for the samples of semi-solid and solid materials shall be friction-top cans.

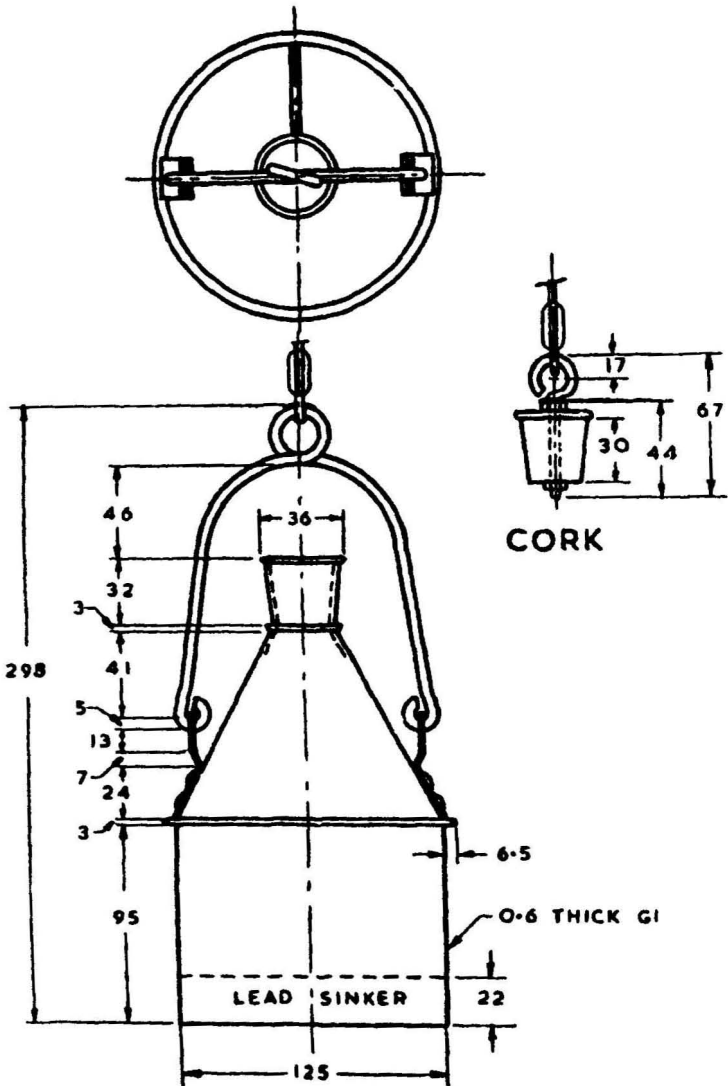

NOTE — A tolerance of 10 percent is allowable on dimensions in millimetres.

FIG. 5 BOTTLE SAMPLER FOR TANK CARS

5.2 The size of the sample container used shall be such that it is nearly filled by the sample taken, just enough free space, such as 5 to 10 percent of the capacity of the container being left to allow for expansion and to enable the contents to be mixed by shaking.

6. SIZE OF SAMPLES

6.1 The sizes of samples to be taken for testing shall be as follows:

a) *Liquid Materials*

- 1) From small containers, cans, drums and barrels — one litre for each separate sample.
- 2) From bulk storage tanks and drums — 5 litres.

b) *Semi-solid or Solid Materials*

- 1) From barrels, drums, cakes and powdered materials in bags — 1 to 2 kg for each separate sample.
- 2) From bulk a minimum of 4.5 kg composite or average sample.

7. PROCEDURE AND SCALE OF SAMPLING

7.1 From Cans or Small Containers, Barrels, Drums and Bags

7.1.1 *Liquid Materials* — The number of packages to be selected for sampling from the lot shall be in accordance with col 1 and 2 of Table 1. The sample packages shall be selected at random.

TABLE 1 SCALE OF SAMPLING

(Clauses 7.1.1 and 7.12)

NO. OF CONTAINERS/ BAGS IN THE LOT	NO. OF CONTAINERS/ BAGS TO BE SELECTED FOR SAMPLING
1	1
2 to 15	2
16 „ 50	3
51 „ 150	5
151 „ 500	8
501 and above	13

7.1.1.1 *Composite sample* — From each of the packages selected for sampling a small quantity of material shall be withdrawn with the help of a sampling tube in accordance with the procedure given in 7.1.1.2. The quantity so withdrawn from each of the packages shall be fully representative and proportional to its contents. The material withdrawn from all the packages shall be thoroughly mixed together and then the requisite quantity for testing shall be withdrawn. This shall be the composite sample. An identical composite sample if required

may also be made for keeping as reference sample under the joint seals of the purchaser and the seller. If the composite sample passes in respect of all the requirements of the specification the lot may be considered to be in conformity to the requirements of the specification.

7.1.1.2 A sampling tube of convenient size shall be lowered into the package so that it touches the bottom, and a sample obtained by closing the top end of the tube with the thumb and withdrawing the tube. If the tube contains free water its contents shall be rejected and the tube again lowered into the package to such a depth as to avoid the water. The tube shall then be withdrawn as before and its contents used to rinse the tube and sample container and then discarded. The tube shall next be lowered slowly as far as possible into the contents of the drum or can, without touching the water layer, if present. The tube shall then be closed and withdrawn and the sample allowed to flow gently and without splashing into a sample container.

7.1.2 *Semisolid or Solid Materials* — The number of packages to be selected for sampling from the lot shall be in accordance with col 1 and 2 of Table 1. The sample packages shall be selected at random.

7.1.2.1 From each of the sample packages from the lot appropriate quantity shall be taken. For this purpose an appropriate sampling apparatus, aid or device may be used which may involve use of hammer, chisel, knife or spatula, auger or a scoop. If the material is held in small containers with a bung-hole too small to introduce the thief, the contents of the container shall be mixed thoroughly by shaking and the requisite quantity of sample shall be poured out. Care shall be taken to ensure that from each container the material taken is fully representative and proportional to its contents. The material so taken from each of the sample containers shall be thoroughly mixed together or melted together if necessary to form a combined mass of material from which a suitable sample for testing shall be taken. This shall be called the composite sample. If required a similar composite sample may be taken for purpose of preservation for reference under the joint seals of purchaser and the seller. The composite sample shall be required to pass all the specified requirements in order to declare a lot to be in conformity to the requirements of this specification.

7.2 From Rail Tank Wagon and Road Tank Trucks/Lorries

7.2.1 A careful observation of the condition of the material in regard to the presence of foam, sediment, or free water on top or at the bottom of the material in the wagon/truck shall be made immediately before sampling, and, if such extraneous materials are present in measurable quantities their volume shall be estimated and samples of each shall

IS : 1201 - 1978

be taken and properly labelled. If possible, the foreign materials shall be removed and discarded before sampling.

7.2.2 Liquid bituminous materials shall, if practicable, be sampled before heating, but if heating is necessary, at no time shall the temperature exceed that required for satisfactory sampling. Semisolid or solid bituminous materials shall be rendered fluid by heating.

7.2.3 When possible, thoroughly mix the material to be sampled by circulating for several hours before samples are taken. Collect the sample from the draw-off cock at the bottom of the tank in the bitumen sampler. When it is not possible to mix the contents of the tank, or when it is desired to ascertain if the contents of the tank are uniform, take samples by means of a bottle sampler by the method described in 7.3.1. Close the sample container immediately.

7.2.4 From each tank wagon/truck the requisite quantity of material shall be taken to constitute the composite sample for testing. If the composite sample is found to pass all the tests, the material in the tank wagon/truck shall be considered to be in conformity to the requirement of the specification. If required an identical composite sample may be taken for reference.

7.3 From Bulk Storage

7.3.1 Liquid Materials and Materials Made Liquid by Heating — The inlet and outlet to the storage tank shall be closed and a 5-litre sample drawn from the top, middle and bottom contents. The sample may be taken from drain cocks on the side of the tank if such are available, with the help of a sampler illustrated in Fig. 1 and when so taken, enough material shall be allowed to flow through the drain cocks and discarded to ensure a representative sample from the contents of the tank. Otherwise samples may be taken by lowering into the material a suitable bottle sampler, a satisfactory type of which is illustrated in Fig. 5. The bottle or can shall be fitted with a stopper which shall be removed by a string or wire attached to it after it has been lowered to the proper depth. The three samples from bulk storage may be tested separately for consistency in order to detect stratification. They may then be combined, thoroughly, mixed, and a 5-litre sample taken therefrom for other tests that may be required for determining average characteristics of the material.

7.3.2 Solid Materials in Loose Form — Mix the piece representing the total quantity on a clean hard surface and proceed as follows:

Place the broken down samples on a clean impervious surface, mix by shovelling and heap into a cone by depositing separate small quantities one on top of the other, the cone being formed symmetrically throughout, with its apex always in the same vertical line.

Alternatively, shovel the material into a funnel having a short cylindrical stem about 51 mm in diameter. Support this funnel in a vertical position above the top of the cone, and raise it (without lateral displacement) as the cone grows higher to allow the material to flow out gently and not fall from a height. Form a new cone twice in a similar way, flatten the third cone by pressing it with a metal sheet or any other suitable appliance, the flattening being carried out symmetrically, thus giving a mass of approximately uniform thickness and diameter. Divide the sample at this stage in quarters by pressing through it a metal cross constructed from four arms or blades which meet at a common centre, held at right angles to each other by stays. Remove a pair of opposite quarters completely and reject them. Mix the two remaining quarters together thoroughly, reduce in bulk by further quartering, and repeat the procedure until a final sample of suitable quantity is left.

The gross sample shall not be less than 25 kg from which shall be selected 1 to 1.5 kg of the composite sample for tests. If the composite sample satisfies all the specified tests, the material in the lot shall be declared to be in conformity to the specified requirements.

8. PRECAUTIONS

8.1 In addition to the general precautions given in 8.2 in sampling for certain tests there are special precautions, which shall be observed and these are prescribed under the relevant method of tests. It cannot be over emphasized that the most careful work in the laboratory or in oil measurement may be rendered useless if care is not taken when drawing the samples upon which such work is based.

8.2 A sample shall not include material other than that to be sampled and shall not become altered, for example by evaporation of volatile constituents or by oxidation, in the process of sampling. The following precautions shall be observed in sampling:

- a) Official samples shall be taken by, or under the immediate supervision of a person of judgement, skill and experience in sampling.
- b) The sampling apparatus, including cords or other ancillary gear, and sample containers shall be dry and free from any substance which will contaminate the product.
- c) The sampling apparatus shall be filled and allowed to drain at least twice before drawing the sample and the sample container shall be rinsed at least twice with the material obtained during the third or any subsequent filling of the sampling apparatus and shall be allowed to drain before being used to contain the actual sample. This shall not apply when such filling, emptying, and rinsing are precluded by the sampling method being employed or by the nature of the material sampled.

IS : 1201 - 1978

- d) During sampling operations, the material being sampled shall be protected as far as possible from the effects of wind and weather, and the sample containers shall be closed immediately after the sample has been taken.
- e) The operator engaged in sampling shall have clean hands free from any material (unless it be the material being sampled). Clean gloves may be worn, but only when essential to protect the operator from some health or other hazard.
- f) Liquid materials in tanks and other bulk containers shall be sampled by the appropriate method described in this standard. The sample shall be drawn through dip hatches, manholes, or other opening giving direct and unconfined access to the bulk of liquid. Samples shall not be drawn from dip-pipes or other fittings, nor shall gauge glasses or drain fittings be used for sampling purposes except where so specified.
- g) The depth of any free water shall be determined before sampling operations are commenced, to ensure that no free water is included in the sample.
- h) If there is any reason to suspect that a sample or a set of samples may not be fully representative, a further sample or set of samples shall be taken. The necessity for taking a second or 'check' sample, or set of samples, is frequently due either to failure or to faulty labelling. The provision of clean apparatus is greatly simplified if separate sampling apparatus, sample containers, and other equipment are reserved and kept separate for different classes of products, while the possibility of errors in labelling may be largely eliminated if each sample is clearly marked before the next sample is taken. All metal sampling gear shall be made of non-spark generating materials.
- j) Glass stoppers shall be glued to the neck of the body. Screw caps of cans shall be fitted with washers of cork or other oil-resisting materials. Corks and stoppers shall be tied or wired on.
- k) Rubber stoppers and corks shall not be used for closing any vessel containing samples of tar and bitumen.
- m) Care shall be taken to see that nothing in the sampling procedure leads to contamination of the stock, for example, by dirt or other extraneous matter picked up by a wet bung, by fragments of stoppers or by other foreign matter and the sample containers are perfectly clean and dry before filling.
- n) It is advisable to take more than one set of samples for check purposes in case of dispute, leakage or breakage in transit or for any other reasons.
- p) Every possible precaution against fire hazard shall be taken when sampling flammable materials like cutback bitumens, etc.

9. LABELLING, PACKING AND STORAGE OF SAMPLES AND SAMPLE CONTAINERS

9.1 Labelling — Sample containers shall be labelled; gummed labels may be used on glass surfaces, but in general wired-on labels shall be preferred. Labels shall be permanently marked. If a pencil is used, sufficient pressure shall be exerted to indent the paper. The following information shall be recorded on the label:

- a) Sample reference number;
- b) Place at which sample was drawn;
- c) Date of sampling;
- d) Initials or other identification mark of sampling officer;
- e) Grade of material;
- f) Quantity represented by sample;
- g) Tank No., package No. (and type), name of the point of despatch;
- h) Type of container from which sample was drawn and type of sample (top, middle average, etc); and
- j) The name of the manufacturer, if known.

9.1.1 The above details shall also be recorded in a book kept separately for the purpose.

9.2 Packing — Sample containers shall be sealed properly to prevent tampering. The type of packing used for samples which are to be transported depends largely on the means of conveyance. Wooden cases or strong cardboard cartons are recommended for cans containing samples. The space round the sample container shall be filled with material, such as saw dust; when such materials are used, the cork or stopper shall be covered with a paper or viscose cap in order to prevent contamination of the sample on opening.

9.3 Storage — Samples of materials which may be affected by light or heat shall be stored in a cool, dark place, periodical examination shall be made for leakage.

As in the Original Standard, this Page is Intentionally Left Blank

Indian Standard
**METHODS FOR TESTING
 TAR AND BITUMINOUS MATERIALS:
 DETERMINATION OF SPECIFIC GRAVITY**
(First Revision)

(Incorporating Amendment Nos. 1 & 2)

1. SCOPE

1.1 This standard covers the methods for the determination of specific gravity of asphalt, bitumen, bituminous products, road tar, coal tar, coal tar pitch, creosote and anthracene oil.

2. TERMINOLOGY

2.0 For the purpose of this standard, the following definition and those given in IS : 334-1965* shall apply.

2.1 **Specific Gravity** — The ratio of the mass of a given volume of the substance to the mass of an equal volume of water, the temperature of both being specified.

2.1.1 If the temperature of the substance is t_1 and that of water is t_2 the specific gravity S , is denoted by St_1/t_2 ; t_1 and t_2 shall be specified clearly.

2.1.2 The specific gravity of bitumens, fluxed native asphalt, road tars, coal tar pitch and blown bitumen shall be determined at 25°C and that of creosote oil and anthracene oil at 38°C and shall be expressed as specific gravity 25°C/25°C or 38°C/38°C.

3. METHOD A (PYKNOMETER METHOD)

3.1 This method covers the determination of specific gravity for semi-solid bitumen road tars and creosote and anthracene oil.

3.2 **Apparatus** — Specific gravity bottles of 50 ml capacity shall be used. One of the two types of specific gravity bottles, namely (a) the ordinary capillary type specific gravity bottle with a neck of 6 mm diameter (see Fig. 1A) and (b) the wide-mouthed capillary type specific gravity bottle (see Fig. 1B) with a neck of 25 mm diameter shall be used.

The stopper shall be provided with a bore 1.0 to 2.0 mm in diameter, centrally located in reference to the vertical axis. The top surface of the stopper shall be smooth and substantially plain and the lower surface shall be concave in order to allow all air to escape through the bore. The height of the concave section shall be 4.0 to 6.0 mm at the centre.

*Glossary of terms relating to bitumen and tar (revised).

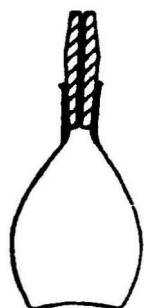

FIG. 1A ORDINARY
CAPILLARY TYPE
SPECIFIC GRAVITY
BOTTLE

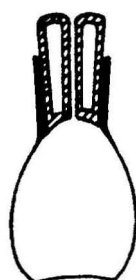

FIG. 1B WIDE-MOUTHED
CAPILLARY TYPE
SPECIFIC GRAVITY
BOTTLE

3.2.1 The ordinary specific gravity bottle shall be used for materials which remain absolutely fluid at 25°C while the wide mouth capillary type shall be used for materials which remain semisolid or high viscous at 25°C.

3.2.2 *Constant Temperature Bath* — A water bath having a depth greater than that of Pyknometer capable of being maintained within 0.2°C of the desired temperature.

3.2.3 *Bath Thermometer* — It shall conform to the following requirements:

Characteristic	Requirement
Range	0 to 44°C
Graduations	0.1°C
Immersion	65 mm
Overall length	340 ± 10 mm
Stem diameter	5.5 to 8.0 mm
Bulb length	10 to 16 mm
Bulb diameter	Not larger than stem diameter
Length of graduated portion	150 to 190 mm
Longer lines at each	1°C and 5°C
Figured at each	5°C
Scale	± 0.1°C

3.3 Procedure — Clean, dry and weigh the specific gravity bottle together with the stopper (a). Fill it with freshly boiled and cooled distilled water and insert the stopper firmly. Keep the bottle up to its neck for not less than half an hour in a beaker of distilled water maintained at a

temperature of $27.0 \pm 0.1^\circ\text{C}$ or any other temperature at which specific gravity is to be determined; wipe all surplus moisture from the surface with a clean, dry cloth and weigh again (b). After weighing the bottle and water together (b) the bottle shall be dried again.

3.3.1 In the case of solids and semisolids, bring a small amount of the material to a fluid condition by gentle application of heat, care being taken to prevent loss by evaporation. When the material is sufficiently fluid, pour a quantity into the clean, dry specific gravity bottle mentioned at 3.3 to fill at least half. Slightly warm the bottle before filling. Keep the material away from touching the sides above the final level of the bottle and avoid the inclusion of air bubbles. The use of a small funnel will prevent contamination of the neck of the bottle. To permit escape of entangled air bubbles, allow the partly filled bottle to stand for half an hour at a temperature between $60 - 70^\circ\text{C}$, then cool to the specified temperature and weigh with the stopper (c).

3.3.2 Fill the specific gravity bottle containing the asphalt with freshly boiled distilled water placing the stopper loosely in the specific gravity bottle. Do not allow any air bubble to remain in the specific gravity bottle. Place the specific gravity bottle in the water bath and press the stopper firmly in place. Allow the specific gravity bottle to remain in the water bath for a period of not less than 30 minutes. Remove the specific gravity bottle from the water bath, wipe all surplus moisture from the surface with a clean dry cloth and weigh it along with the stopper.

3.3.3 In the case of liquids such as creosote and anthracene oil, fill the bottle up to the brim and insert the stopper firmly. Keep the filled bottle for not less than half an hour in a beaker of distilled water maintained at a temperature of $27.0 \pm 0.1^\circ\text{C}$, remove the bottle from the beaker, wipe all surplus water from the surface with a clean, dry cloth and weigh again.

3.4 Calculation — Calculate the specific gravity of the material as follows:

- a) Specific gravity (solids and semisolids) $= \frac{c - a}{(b - a) - (d - c)}$
- b) Specific gravity (liquids) $= \frac{e - a}{b - a}$

where

- a = mass of the specific gravity bottle,
 b = mass of the specific gravity bottle filled with distilled water,
 c = mass of the specific gravity bottle about half filled with the material,

IS : 1202 - 1978

d = mass of the specific gravity bottle about half filled with the material and the rest with distilled water, and

e = mass of the specific gravity bottle completely filled with the material.

3.5 Report — Results of the test shall be expressed as the ratio of mass of a given volume of the material at a temperature specified under 2.1.2 to the mass of the same volume of water at the same temperature.

3.6 Precision — With samples which are neither very volatile nor very viscous and using a pyknometer of at least 25 ml capacity, the results of duplicate tests should not differ by the following:

Repeatability
0.002

Reproducibility
0.005

3.7 Precautions — When making the specific gravity determination, it is important that:

- a) only freshly boiled and cooled distilled water shall be used;
- b) at no time of weighing shall the temperature of the apparatus be allowed to exceed the specified temperature;
- c) precautions shall be taken to prevent expansion and over-flow of the contents resulting from the heat of the hand when wiping the surface of the apparatus;
- d) all air bubbles shall be eliminated in filling the apparatus and inserting the stopper;
- e) weighing shall be done quickly after filling the apparatus and shall be accurate to 0.1 mg; and
- f) to prevent breakage of the apparatus when cleaning after a determination has been made upon a very viscous or semisolid material, it is advisable to warm it in an oven at a temperature not above 100°C, until most of the material is poured out and then to swab it with a piece of soft cloth or cotton waste. When cool, it may be finally rinsed with carbon disulphide, benzol or other solvent and wiped clean.

4. METHOD B (BALANCE METHOD)

4.1 This balance method of test is intended for the determination of the specific gravity of all bituminous materials sufficiently solid to be handled in fragments.

4.2 Apparatus

4.2.1 Balance Analytical

4.2.2 Thermometer — as given in Method A.

4.2.3 Balance Straddle — A pan straddle of convenient size to support a beaker and permit determination of the weight of the specimen in water (see Fig. 2).

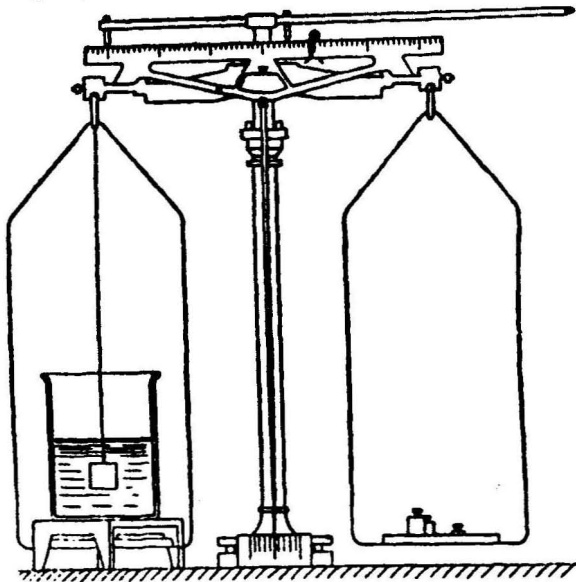

FIG. 2 ANALYTICAL BALANCE EQUIPPED WITH PAN STRADDLE

4.2.4 Thread — A length of fine, waxed, silk thread.

4.2.5 Brass Moulds — cubical, measuring approximately 20 mm on each edge.

4.3 Test Specimen — The test specimen shall be a cube of the material measuring approximately 20 mm on each edge. Prepare the specimen by melting a small sample of the material by gentle application of heat, taking care to prevent loss by evaporation, and pouring the material when sufficiently fluid into a 20 mm brass cubical mould that has been treated with a 1 : 1 mixture of glycerine and dextrin and placed on a brass plate previously so treated. Take precautions to prevent the inclusion of air bubbles. The hot material should be slightly more than that required to fill the mould, and when cool, the excess may be cut off with a hot spatula. Remove the specimen from the mould when cooled to room temperature.

4.4 Procedure — Tare the balance first with a piece of fine waxed silk thread sufficiently long to reach from the hook on one of the pan

IS : 1202 - 1978

supports to the rest. Attach the test specimen to the thread, so as to be suspended about 25 mm above the straddle from the hook on the pan support, and weigh to the nearest 0.1 mg. Weigh the specimen, still suspended by thread, and completely immersed in freshly boiled and cooled distilled water at $27.0 \pm 0.1^\circ\text{C}$, to the nearest 0.1 mg, adhering air bubbles being first removed with a fine wire.

4.5 Calculation — Calculate the specific gravity of the material as follows:

$$\text{Specific gravity} = \frac{a}{a - b}$$

where

a = mass of the dry specimen, and

b = mass of the specimen when immersed in distilled water.

4.6 Report — Report the specific gravity to the nearest 0.001 at $25^\circ\text{C}/25^\circ\text{C}$. The buoyancy/correction in this case is negligible.

4.7 Precision — The duplicate results shall not differ by more than the following:

<i>Size of Sample</i>	<i>Repeatability</i>	<i>Reproducibility</i>
5 g or larger	0.005	0.007

Indian Standard
METHODS FOR TESTING
TAR AND BITUMINOUS MATERIALS:
DETERMINATION OF PENETRATION
(*First Revision*)

(Incorporating Amendment Nos. 1 & 2)

1. SCOPE

1.1 This standard covers the method for the determination of penetration of asphaltic bitumen and fluxed native asphalt and blown type bitumen.

2. TERMINOLOGY

2.0 For the purpose of this standard, the following definition and those given in IS : 334-1965* shall apply.

2.1 **Penetration** — The penetration of a bituminous material is the distance in tenths of a millimetre that a standard needle will penetrate vertically into a sample of the material under standard conditions of temperature, load and time.

3. APPARATUS

3.1 **Container** — A metal or glass cylindrical, flat bottom container of essentially the following dimensions shall be used:

For penetrations below 225:

Diameter, mm	55
Internal depth, mm	35

For penetrations between 225 and 350:

Diameter, mm	70
Internal depth, mm	45

3.2 **Needle** — A straight, highly polished, cylindrical, stainless steel (SS 316) rod, with conical and parallel portions co-axial, having the shape, dimensions and tolerances given in Fig. 1. The needle is provided with a shank approximately 3 mm in diameter into which it is immovably fixed. The taper shall be symmetrical and the point shall be 'blunted' by grinding to a truncated cone.

*Glossary of terms relating to bitumen and tar (*revised*).

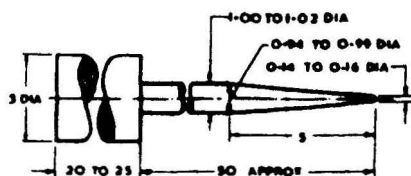

All dimensions in millimetres.

FIG. 1 NEEDLE FOR PENETRATION TEST

3.3 Water Bath — A water bath preferably with a thermostat maintained at $25.0 \pm 0.1^\circ\text{C}$ containing not less than 10 litres of water, the sample being immersed to a depth of not less than 100 mm from the top and supported on a perforated shelf not less than 50 mm from the bottom of the bath.

3.4 Transfer Dish — A small dish or tray, provided with some means which ensure a firm bearing and prevent the rocking of the container, and of such capacity as will ensure complete immersion of the container during the test.

3.5 Penetration Apparatus — Any apparatus which will allow the needle to penetrate without appreciable friction, and which is accurately calibrated to yield results in tenths of millimetre shall be adopted.

3.6 Thermometer — It shall conform to the following requirements:

<i>Characteristic</i>	<i>Requirement</i>
Range	0 to 44°C
Graduations	0.2°C
Immersion	65 mm
Overall length	340 ± 10 mm
Stem diameter	5.5 to 8.0 mm
Bulb length	10 to 16 mm
Bulb diameter	Not larger than stem diameter
Length of graduated portion	150 to 190 mm
Longer lines at each	1°C and 5°C
Figured at each	5°C
Scale	$\pm 0.2^\circ\text{C}$

3.7 Time Device — For hand-operated penetrometers, any convenient timing device, such as electric timer, stop watch, or any other spring actuated device may be used provided it is graduated 0.1 s or less and is

accurate to within ± 0.1 s for a 60-s interval. An audible seconds counter adjusted to provide 1 beat each 0.5 s may also be used. The time for a 11-count interval shall be 5 ± 0.1 s. Any automatic timing device attached to a penetrometer shall be accurately calibrated to provide the desired test interval within ± 0.1 s.

4. PROCEDURE

4.1 Preparation of Test Sample

4.1.1 Soften the material to a pouring consistency at a temperature not more than 60°C for tars and pitches and not more than 90°C for bitumens above the respective approximate softening point and stir it thoroughly until it is homogeneous and is free from air bubbles and water. Pour the melt into the container to a depth at least 10 mm in excess of the expected penetration. Protect the sample from dust and allow it to cool in an atmosphere at a temperature between 15 to 30°C for $1\frac{1}{2}$ to 2 h for 45 mm deep container and 1 to $1\frac{1}{2}$ h when the container of 35 mm depth is used. Then place it along with the transfer dish in the water bath at $25.0 \pm 0.1^{\circ}\text{C}$ and allow it to remain for $1\frac{1}{2}$ to 2 h and 1 to $1\frac{1}{2}$ h for 45 mm and 35 mm deep container respectively.

4.1.2 In the case of cutback bitumen and Digboi type cutback bitumen, residue left after distillation shall be used for the test. The procedure for handling the residue shall be in accordance with the method described under 3.2.4 of the distillation test (see IS : 1213-1978*).

4.2 Testing

4.2.1 Unless otherwise specified, testing shall be carried out at $25.0 \pm 0.1^{\circ}\text{C}$.

4.2.2 Fill the transfer dish with water from the water bath to a depth sufficient to cover the container completely; place the sample in it and put it upon the stand of the penetration apparatus. Adjust the needle (previously washed clean with benzene, carefully dried, and loaded with the specified weight) to make contact with the surface of the sample.

4.2.2.1 This may be accomplished by placing the needle point in contact with its image reflected by the surface of the material from a suitably placed source of light.

4.2.2.2 Unless otherwise specified, load the needle holder with the weight required to make a total moving weight (that is, the sum of the weights of the needle, carrier and superimposed weights) of 100 ± 0.25 g.

*Methods for testing tar and bituminous materials: Distillation test (first revision).

IS : 1203 - 1978

4.2.3 Note the reading of the dial or bring the pointer to zero. Release the needle and adjust the points, if necessary to measure the distance penetrated. Make at least three determinations at points on the surface of the sample not less than 10 mm apart and not less than 10 mm from the side of the dish. After each test, return the sample and transfer dish to the water bath, and wash the needle clean with benzene and dry. In the case of material of penetration greater than 225, three determinations on each of two identical test specimens using a separate needle for each determination shall be made, leaving the needle in the sample on completion of each determination to avoid disturbance of the specimen.

4.2.4 For determining the penetration ratio, testing shall also be carried out at $4.0^\circ \pm 0.1^\circ\text{C}$.

NOTE — For test at 4°C , the total weight on the penetration needle shall be 200 ± 0.25 g and the time of penetration shall be 60 s.

5. REPORT

5.1 Express the depth of penetration of the needle in tenths of millimetre.

5.2 The value of penetration reported shall be the mean of not less than three determinations whose values do not differ by more than the amount given below:

<i>Penetration</i>	<i>Maximum Difference</i>
0 to 49	2
50 to 149	4
150 to 249	6
250 and above	8

5.3 Determine the penetration ratio as under:

$$\text{Penetration ratio} = \frac{\text{Pen. at } 4^\circ\text{C} \cdot 200 \text{ g} \cdot 60 \text{ s}}{\text{Pen. at } 25^\circ\text{C} \cdot 100 \text{ g} \cdot 5 \text{ s}} \times 100$$

6. PRECISION

6.1 The duplicate results should not differ by more than the following:

<i>Penetration</i>	<i>Repeatability</i>	<i>Reproducibility</i>
Below 50	1 Unit	4 Units
Above 50	3 percent of their mean	8 percent of their mean

7. PRECAUTIONS

7.1 If the sample contains extraneous matter, it should be sieved through IS Sieve 30 (see IS : 460-1962*).

7.2 To avoid overheating at the bottom of the container, use of an air-oven or sand bath is recommended.

7.3 While the needle is penetrating into the sample, if there is any movement of the container, that determination shall be discarded.

*Specification for test sieves (revised).

Indian Standard
**METHODS FOR TESTING
TAR AND BITUMINOUS MATERIALS:
DETERMINATION OF RESIDUE OF
SPECIFIED PENETRATION**
(First Revision)

1. SCOPE

1.1 This standard covers the method for the determination of residue of specified penetration of cutback bitumens.

2. TERMINOLOGY

2.0 For the purpose of this standard, the following definition and those given in IS : 334-1965* shall apply.

2.1 Residue of Specified Penetration — It is the percentage by mass of a residue obtained by heating a bituminous material to the required temperature and having a specified standard penetration value.

Alternatively, the determination of residue of specified penetration is made at two stages, one giving a penetration higher than 100 and the other lower than 100, and the result is obtained by interpolation.

3. APPARATUS

3.1 Container — A flat-bottomed, cylindrical seamless tin dish 70 mm in diameter and 45 mm in depth.

3.2 Heating Bath — A cast iron bath with the shape and dimensions as shown in Fig. 1 permitting the immersion of the container to a depth of 32 mm through an opening 1.6 mm larger in diameter than the container. It shall be provided with three rivets or bolts so as to support the container 6 mm above the hot plate. The free air space between the sides of the container and of the air bath below the opening shall be not less than 6 mm.

*Glossary of terms relating to bitumen and tar (revised).

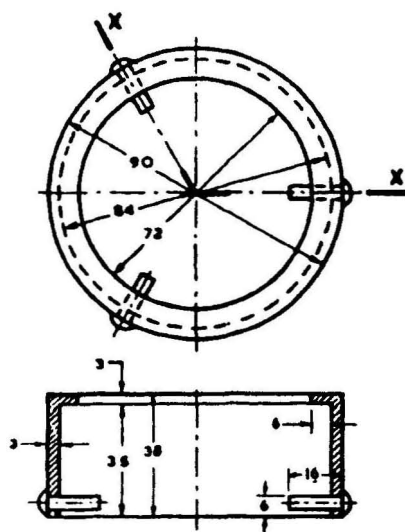

SECTION XX

All dimensions in millimetres.

FIG. 1 HEATING BATH

3.3 Hot Plate — Suitably mounted and heated either electrically or by means of a gas flame, capable of maintaining the sample continuously at the required temperature, provided with an apparatus, such as a rheostat or gas pressure regulator.

3.4 Thermometer — An open flash thermometer having the range from minus 6°C to plus 400°C shall conform to the following:

Immersion	25 mm
Temperature range	- 6°C to + 400°C
Subdivision	2°C
Longer graduation lines at each	10°C
Graduation numbered at each multiple of	20°C
Scale error at any point up to 372°C when standardized shall not exceed	1°C

3.5 Needle — as specified under 3.2 of IS : 1203-1978*.

*Methods for testing tar and bituminous materials : Determination of penetration (first revision).

3.6 Water Bath — as specified under **3.3** of IS : 1203-1978*.

3.7 Penetration Apparatus — as specified under **3.5** of IS : 1203-1978*.

4. PROCEDURE

4.1 Preparation of Sample

4.1.1 Thoroughly stir and agitate the material as received to ensure a complete mixture before the portion for testing is removed. If the sample contains extraneous matter, it should be sieved through IS Sieve 30.

4.2 Weigh a 100.00 ± 0.10 g sample of the material to be tested into the tared container, and place the container in the air bath in position to be heated. Support the thermometer in the sample equidistant from the sides of the container, with the bottom of the bulb neither more than 6 mm above nor touching the bottom of the container. Immerse the bulb completely in the sample and keep it immersed throughout the heating. Heat the sample as rapidly as possible, without foaming, to a temperature of 249°C and during the evaporation maintain the temperature between 249°C and 260°C . Stir the sample from time to time to prevent local overheating and, to maintain a homogeneous sample, flux in the sample all cakes of hardened bitumen which form at the sides of the container.

4.2.1 An experienced operator would be able to judge approximately the consistency of the residue he should obtain to secure the desired penetration when it is judged that the residue might show the required penetration, return to the container the bitumen on the thermometer which may be readily scraped off. Remove the container from the airbath, cool and weigh.

4.3 Determine the penetration of the residue in accordance with **4.2** of IS : 1203-1978* with the exception that the container as specified in **3.1** in which the evaporation has been conducted, shall be used.

4.4 Frequently, it is necessary to make several trials before a residue of the required penetration is obtained. If it is found to be of greater value than required, remove all water from the container and the surface of the sample, and repeat the heating and determination of penetration as before. Ordinarily, a residue is considered as satisfactorily obtained when its penetration is 100.

4.4.1 When it is necessary to determine more precisely the percentage of residue having a penetration of 100, such as a percentage shall be calculated by interpolation between percentages of two residues, one having a penetration greater and one having a penetration lower than 100.

*Methods for testing tar and bituminous materials : Determination of penetration (first revision).

IS : 1204 - 1978

5. REPORT

5.1 Calculate the percentage by weight of the original samples and report it as the percentage residue of 100 penetration, stating whether the penetration was actually determined for the sample tested or calculated by interpolation.

6. PRECISION

6.1 Duplicate determinations by this method shall not differ from each other by more than 1.0 percent with the same operator, and not more than 2.5 percent between different laboratories.

7. PRECAUTION

7.1 Certain types of cut back bitumens readily form rings of hard bitumen at the side of the container. Care shall be taken that this material is completely fluxed into the sample before the penetration of residue is determined.

Indian Standard

**METHODS FOR TESTING
TAR AND BITUMINOUS MATERIALS:
DETERMINATION OF SOFTENING POINT**

(First Revision)

1. SCOPE

1.1 This standard covers the method for the determination of softening point of asphaltic bitumen and fluxed native asphalt, road tar, coal tar pitch and blown type bitumen.

2. TERMINOLOGY

2.0 For the purpose of this standard, the following definition and those given in IS : 334-1965* shall apply.

2.1 Softening Point — The temperature at which the substance attains a particular degree of softening under specified condition of test.

3. APPARATUS

3.1 Ring and Ball Apparatus — A convenient form of apparatus is illustrated in Fig. 1.

3.1.1 Steel Balls — two; each 9.5 mm in diameter and weighing 3.50 ± 0.05 g.

3.1.2 Brass Rings — two; the rings shall be tapered (see Fig. 2) and shall conform to the following dimensions:

Depth	6.4 ± 0.1 mm
Inside diameter at bottom	15.9 ± 0.1 mm
Inside diameter at top	17.5 ± 0.1 mm
Outside diameter	20.6 ± 0.1 mm

*Glossary of terms relating to bitumen and tar (revised).

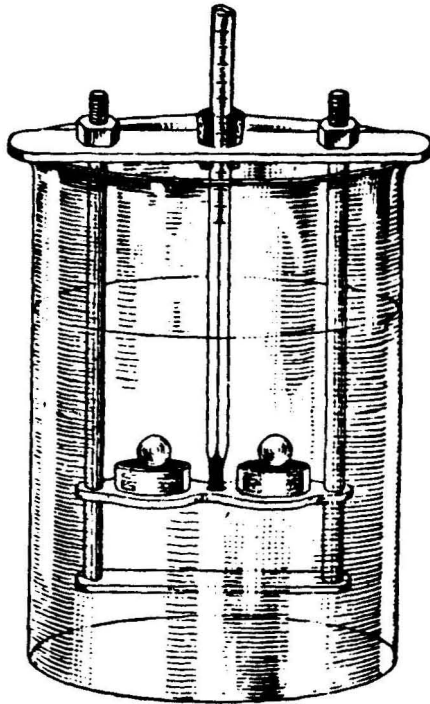

FIG. 1 ASSEMBLY OF APPARATUS FOR DETERMINATION OF SOFTENING POINT (RING AND BALL — TWO RINGS)

For convenience in mounting the rings in a support of the type shown in Fig. 1 to 4, the outside diameter of the ring at the bottom may be smaller, but shall be not less than 19.0 mm.

3.1.3 Ball Guide — A convenient form of ball centering guide. A recommended form of ball guide is illustrated in Fig. 3.

3.1.4 Support — Any means of supporting the rings may be used provided the following conditions are observed:

- a) The rings shall be supported in a horizontal position with the upper surface of the rings 50 mm below the surface of the bath liquid.
- b) There shall be a distance of exactly 25 mm between the bottom of the rings and the top surface of the bottom plate of the support, if any, or the bottom of the bath.

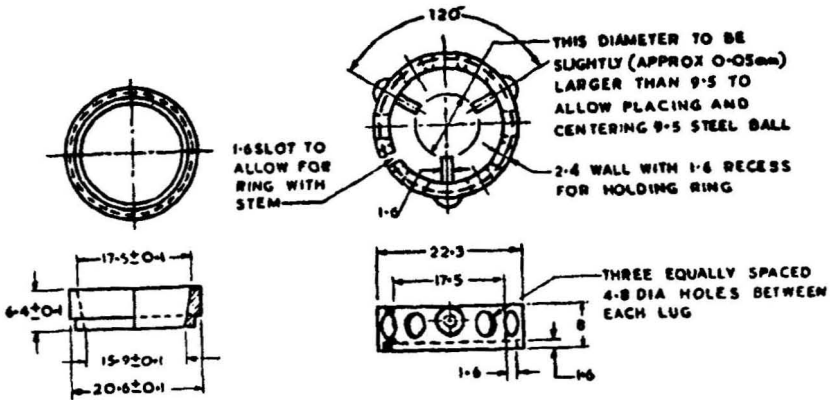

All dimensions in millimetres.

FIG. 2 TAPERED RING

All dimensions in millimetres.

FIG. 3 BALL CENTERING GUIDE

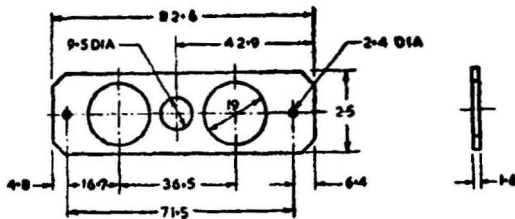

All dimensions in millimetres.

FIG. 4 RING HOLDER

- c) The thermometer shall be suspended so that the bottom of the bulb is level with the bottom of the rings, and within 10 mm of the rings, but not touching them.

3.1.5 Thermometer — It shall be of the mercury-in-glass type, nitrogen filled, with the stem made of lead glass or other suitable glass. It shall be engraved and enamelled at the back and provided with an expansion chamber and glass ring at the top. The bulb shall be cylindrical, made of suitable thermometric glass. The dimensions,

IS : 1205 - 1978

tolerances and graduations of the thermometer shall be as follows:

	<i>Low Temperature</i>	<i>High Temperature</i>
Range	- 2°C to 80°C	30 to 200°C
Graduation at each	0.2°C	0.5°C
Longer lines at each	1°C	1°C
Figured at each	2°C	5°C
Immersion, mm	Total	Total
Overall length	378 to 384 mm	378 to 384 mm
Length of graduated portion	243 to 279 mm	243 to 279 mm
Length of bulb, <i>Max</i>	9 to 14 Not larger than stem diameter	9 to 14 mm Not larger than stem diameter
Stem diameter	6.0 to 7.0 mm	6.0 to 7.0 mm
Distance from bottom of bulb to 0°C	75 to 90 mm	75 to 90 mm
Scale error, <i>Max</i>	± 0.2°C	± 0.3°C

3.1.6 Bath — a heat resistance glass vessel not less than 85 mm in diameter and 120 mm in depth. The bath liquid shall be freshly boiled with distilled water when testing materials having softening points below 80°C, and pure glycerine for materials having softening points above 80°C.

3.1.7 Stirrer — manual or mechanical, which operates smoothly to ensure uniform heat distribution at all times throughout the bath. The stirrers shall be so placed that the moulds are not disturbed when the stirrer is in operation.

4. PROCEDURE

4.1 Preparation of Test Sample — Heat the material to a temperature between 75°C and 100°C above its softening point, stir until it is completely fluid and free from air bubbles and water, and filter, if necessary, through IS Sieve 30 (*see IS : 460-1962**). Place the rings, previously heated to a temperature approximating to that of the molten material, on a metal plate which has been coated with a mixture of equal parts of glycerine and dextrine, and fill with sufficient

*Specification for test sieves (*revised*).

melt to give an excess above the level of the ring when cooled. After cooling for 30 minutes in air, level the material in the ring by removing the excess with a warmed, sharp knife.

4.2 Materials of Softening Point Below 80°C — Assemble the apparatus with the rings, thermometer and ball guides in position, and fill the bath to a height of 50 mm above the upper surface of the rings with freshly boiled distilled water at a temperature of 5°C. Maintain the bath at a temperature of 5°C for 15 minutes after which place a ball, previously cooled to a temperature of 5°C, by means of forceps in each ball guide. Apply heat to the bath and stir the liquid so that the temperature rises at a uniform rate of $5.0 \pm 0.5^\circ\text{C}$ per minute until the material softens and allows the ball to pass through the ring. The rate of temperature rise shall not be averaged over the period of the test, and any test in which the rate of temperature rise does not fall within the specified limits after the first three minutes shall be rejected. Make the determination in duplicate.

4.3 Materials of Softening Point Above 80°C — The procedure for materials of softening point above 80°C is similar to that described under 4.2 with the difference that glycerine is used in place of water in the bath and the starting temperature of the test is 35°C. Make the determination in duplicate.

5. REPORT

5.1 Record for each ring and ball, the temperature shown by the thermometer at the instant the sample surrounding the ball touches the bottom plate of the support, if any, or the bottom of the bath.

5.2 Report to the nearest 0.5°C the mean of the temperature recorded in duplicate determinations, without correction for the emergent stem of the thermometer, as the softening point.

6. PRECISION

6.1 Test results shall not differ from the mean by more than the following:

<i>Softening Point</i> °C	<i>Repeatability</i> °C	<i>Reproducibility</i> °C
40 to 60	1.0	5.5
61 to 80	1.5	5.5
81 to 100	2.0	5.5
101 to 120	2.5	5.5
121 to 140	3.0	5.5

IS : 1205 - 1978

7. PRECAUTIONS

7.1 Only freshly boiled distilled water shall be used in the test, as otherwise air bubbles may form on the specimen and affect the accuracy of the results.

7.2 The prescribed rate of heating shall be rigidly adhered to for ensuring accuracy of results.

7.3 A sheet of filter paper or thin amalgamated sheet, placed on the bottom of the glass vessel and conveniently weighed would prevent the material from sticking to the glass vessel, and considerable time and trouble in cleaning would thereby be saved.

Indian Standard

METHODS FOR TESTING
TAR AND BITUMINOUS MATERIALS:
DETERMINATION OF VISCOSITY

PART I INDUSTRIAL VISCOSITY

(*First Revision*)

(Incorporating Amendment No. 1)

1. SCOPE

1.1 This standard (Part I) covers the methods for the determination of viscosity of bitumen, road tar and cutback bitumens.

2. TERMINOLOGY

2.0 For the purpose of this standard, the following definition and those given in IS : 334-1965* shall apply.

2.1 Industrial Viscosity — The property of a fluid by which it resists flow due to internal friction, and one of the methods by which it is measured, is by determining the time taken by 50 cc of the material to flow from a cup through a specified orifice under standard conditions of test and at specified temperature.

3. METHOD A (VISCOMETER FITTED WITH 10-mm CUP FOR ROAD TAR)

3.1 Apparatus

3.1.1 Tar Viscometer — consists essentially of a cup having a specified orifice and valve; a water bath mounted on three legs having a suitable sleeve for the cup, a stirrer, a shield and a receiver (*see* Fig. 1). The following is the detailed description of the different parts and accessories of tar viscometer:

- a) *Cup* — known as the 10-mm cup, is constructed of hard brass tube of the dimensions shown in Fig. 2 and fitted with an external brass collar at the upper (open) end of the cylinder to support the

*Glossary of terms relating to bitumen and tar (*revised*).

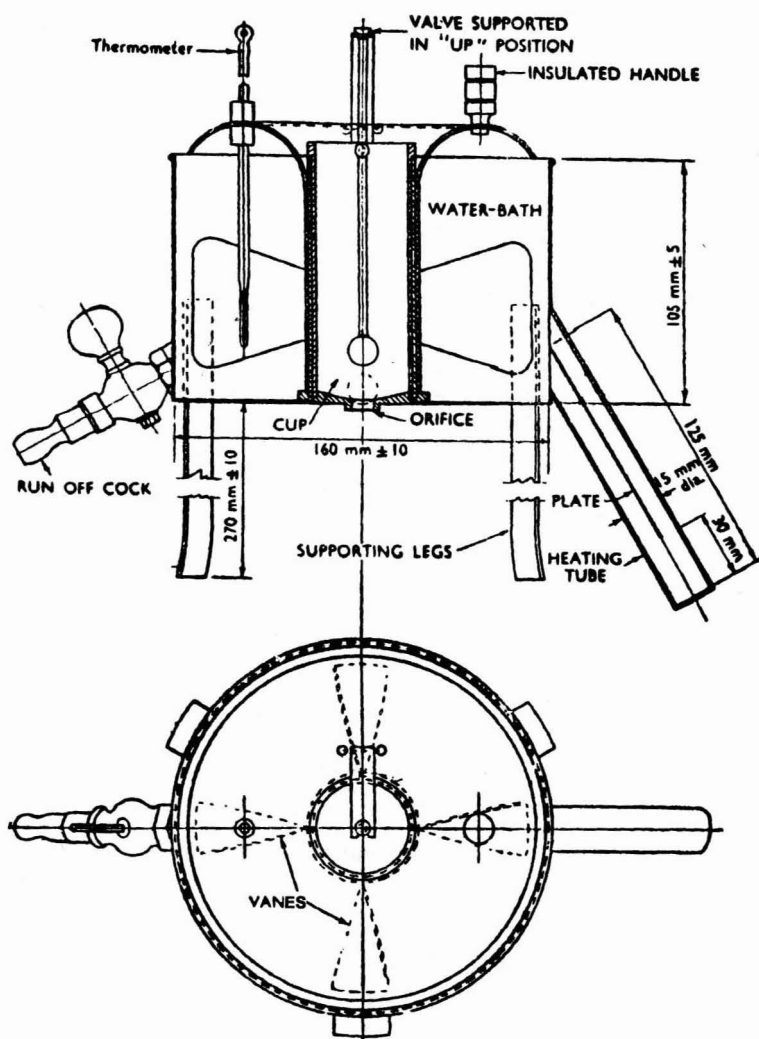
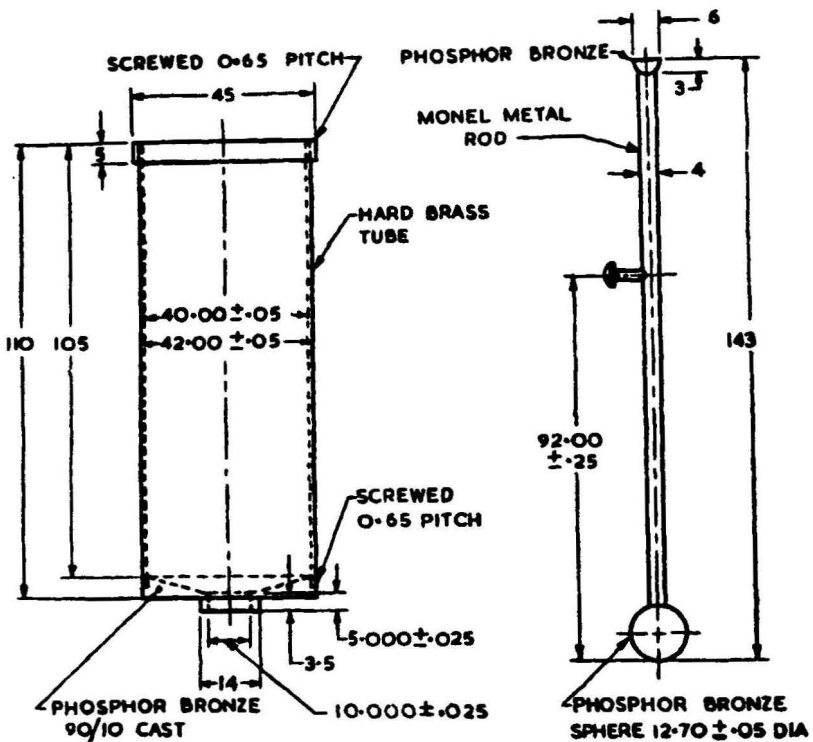

FIG. 1 TAR VISCOMETER



All dimensions in millimetres.

FIG. 2 10-mm TAR CUP AND VALVE

cup in the sleeve of the water bath. The bottom of the cup consists of a circular phosphor-bronze plate screwed into the cylinder and made conical to facilitate drainage of the tar after use. It is provided centrally with a perfectly cylindrical, phosphor-bronze (90/10 cast) extension of the dimensions shown in Fig. 2. The extension is drilled and polished internally to give a 10-mm circular orifice. The upper rim of the orifice shall be perfectly circular in order to provide a seating for the valve.

The dimensions of orifice and jet shall be as follows:

Diameter of the orifice	10.000 ± 0.025 mm
Length of the jet	5.000 ± 0.025 mm

IS : 1206 (Part I) - 1978

- b) *Valve* — shall be of dimensions shown in Fig. 2. It serves to close the orifice of the 10-mm cup and is a phosphor-bronze sphere attached to a monel metal rod. The rod is provided with a levelling peg and at the upper end a hemisphere by which the valve is held in the valve support.
- c) *Water bath* — made of copper sheet, is cylindrical in shape, about 160 mm in diameter and 105 mm in depth. It may be heated electrically, care being taken that local heating is avoided.
- The water bath is mounted on three equidistant legs which are riveted to the cylindrical wall of the bath and are of sufficient length to permit a 100-ml cylinder to be placed below the orifice of the cup.
- d) *Sleeve* — to receive the cup and to hold it in position with an easy sliding fit. It is a stout brass tube, 105 mm in height and 42 mm internal diameter, which is bronzed or soldered into a central hole cut in the bottom of the bath.
- e) *Stirrer* — consists of four vertical vanes, with the upper and lower portions turned in opposite directions, mounted on a cylinder which slips on the sleeve with an easy sliding fit. The cylinder is cut away between the vanes to facilitate heat transfer from the water in the bath to the tar cup; vertical grooves are provided on the inner surface of the cylinder to prevent the water in the bath from being carried into the tar cup, if the stirring system be raised.
- f) *Curved shield* — fixed to the upper edge of the cylinder and extends to within about 5 mm of the walls of the water bath. This shield carries an insulated handle for rotating the stirrer, a support for a thermometer, and a swivelled support for the valve. The two positions of this valve support are respectively (a) well clear of the tar cup, and (b) extending over the tar cup so that the valve, when resting on the support, hangs vertically over and 16 ± 1 mm above the orifice of the tar cup.
- g) *Receiver* — a 100-ml graduated measuring cylinder with graduations at 20 ml, 25 ml and 75 ml capacities, having an internal diameter of not more than 29 mm.
- h) *Thermometers* — two standard thermometers, one for the bath and another for the cup. Both the thermometers shall be of the same range, depending on the temperature at which the determination is being made. The thermometers shall be of mercury in glass tube with cylindrical bulbs and made of suitable thermometer glass and shall conform to the following requirements:

<i>Characteristic</i>	<i>Low</i>	<i>Medium</i>	<i>High</i>
Range	0 to 44°C	37.8 to 82°C	76 to 122°C
Graduations	0.2°C	0.2°C	0.2°C
Immersion	65 mm	65 mm	65 mm
Overall length	340 ± 10 mm	340 ± 10 mm	340 ± 10 mm
Stem diameter	5.5 to 8.0 mm	5.5 to 8.0 mm	5.5 to 8.0 mm
Bulb length	10 to 16 mm	10 to 16 mm	10 to 16 mm
Bulb diameter	←—— Not larger than the stem diameter ——→		
Length of graduated portion	150 to 190 mm	150 to 190 mm	150 to 190 mm
Longer lines at each	1°C and 5°C	1°C and 5°C	1°C and 5°C
Figured at each	5°C	5°C	5°C
Scale	± 0.2°C	± 0.2°C	± 0.5°C

j) *A stop watch or a stop clock or any other timing device* — capable of being read up to half a second.

3.2 Procedure

3.2.1 Adjust the tar viscometer so that the top of the tar cup is level. Heat the water in the water bath to the temperature specified for the test and maintain it within $\pm 0.1^\circ\text{C}$ of the specified temperature throughout its bulk for the duration of the test, the stirrer being gently rotated at frequent intervals or, preferably, continuously.

3.2.2 Clean the tar cup orifice of the viscometer with a suitable solvent and dry thoroughly.

3.2.3 Warm and stir the material under examination to 20°C above the temperature specified for the test, and cool, while continuing the stirring. When the temperature has fallen to slightly above the specified temperature, pour the tar into the tar cup until the levelling peg on the valve rod is just immersed when the latter is vertical.

3.2.4 Pour into the graduated receiver 20 ml of mineral oil, or a one percent by weight solution of soft soap, and place it under the orifice of the tar cup.

3.2.5 Place a second standard thermometer in the tar and stir the latter until the temperature is within $\pm 0.1^\circ\text{C}$ of the specified temperature. When this temperature has been reached, suspend the thermometer co-axially with the cup and with its bulb approximately at the geometric centre of the tar. Allow the assembled apparatus to stand for five minutes during which period the thermometer reading shall remain within

IS : 1206 (Part I) - 1978

0.05°C of the specified temperature. Remove the thermometer and quickly remove any excess of tar so that the final level is on the centre line of the levelling peg when the valve is in vertical position.

3.2.6 Lift the valve and suspend it on the valve support. Start the stop watch or the time recording device when the reading in the cylinder is 25 ml and stop it when it is 75 ml. Note the time in seconds.

3.3 Report

3.3.1 Report the time in seconds taken by 50 ml of the tar to flow out as the viscosity of the sample at the temperature specified for the test.

3.3.2 State clearly whether the sample was dried or tested as received as the presence of water, particularly in quantities less than one percent, has a marked effect on the viscosity. Report the method of drying adopted.

3.4 Precision — The results of repeat determinations on portions of the same sample shall fall within ± 4 percent of the average of several readings.

3.5 Precautions

3.5.1 The working range of the instrument with the 10-mm cup is such that the time of efflux shall be between 10 and 140 seconds.

3.5.2 The temperature of test shall be appropriate to emulate the condition specified under **3.5.1** and shall be a multiple of 5°C, not lower than 20°C.

3.5.3 The tar cup is a critical part of a viscometer and special precautions shall be observed in its treatment and use. Any cleaning process shall be of gentle nature. Non-corroding solvents, such as light tar oils, free from phenols, are recommended rather than mechanical means, such as dusters, which are liable to cause abrasion of the metal, especially at the orifice. If any material be used for rubbing the interior of the cup, it shall not be such as may disintegrate in use, leaving particles which may interfere with the free flow of the sample through the orifice.

3.5.4 The orifice of the tar cup shall be tested at frequent intervals with a gauge having appropriate diameters.

4. METHOD B (VISCOMETER FITTED WITH 4-mm CUP FOR CUTBACK BITUMENS)

4.1 Apparatus — The tar viscometer as specified in Method A shall be used with one modification, namely that the 4-mm cup shall be fitted

instead of the 10-mm cup. The dimensions of orifice and jet shall be as follows:

Diameter of the orifice	4.000 ± 0.025 mm
Length of jet	5.000 ± 0.025 mm

4.2 Procedure — The procedure shall be the same as specified in Method A (see 3.2) except that the 4-mm cup shall be fitted in tar viscometer instead of the 10-mm cup.

4.3 Precautions

4.3.1 The working range for the instrument with the 4-mm orifice is such that the time of efflux shall be between 20 and 200 seconds.

4.3.2 The temperature of test shall be appropriate to ensure the condition specified under 4.3.1 and shall be a suitable multiple of 5°C, not lower than 20°C.

5. REPORT

5.1 Report the viscosity of the sample at the specified temperature for the test, the time in seconds nearest to whole number taken by 50 ml of the tar to flow out.

6. PRECISION

6.1 Results of duplicate tests should not differ by more than the following amount:

<i>Viscosity</i>	<i>Repeatability</i>	<i>Reproducibility</i>
Below 20 s	2 s	2 s
20 to 40 s	2 s	10 percent of the mean
> 40 s	5 percent of the mean	10 percent of the mean

As in the Original Standard, this Page is Intentionally Left Blank

Indian Standard

METHODS FOR TESTING
TAR AND BITUMINOUS MATERIALS:
DETERMINATION OF VISCOSITY

PART II ABSOLUTE VISCOSITY

(*First Revision*)

(Incorporating Amendment Nos. 1 & 2)

1. SCOPE

1.1 This standard (Part II) covers the method for the determination of absolute viscosity of bitumens and cut-backs by vacuum capillary viscometers at any specified temperature. It is applicable to materials having a viscosity range of 42 to 200 000 Poises.

NOTE — The standard covers three types of viscometers and any one of them can be used for determination of absolute viscosity.

2. TERMINOLOGY

2.0 For the purpose of this standard, the following definitions and those given in IS : 334-1965* shall apply.

2.1 Absolute or Dynamic Viscosity of a Newtonian Liquid — It is an internal friction, such that if a tangential force of one dyne (0.000 01 N) acting on planes of unit area separated by unit distance of the liquid produces unit tangential velocity, the cgs unit for the viscosity of the liquid is 1 Poise.

2.2 Newtonian Liquid — A liquid in which the shear stress is directly proportional to the rate of shear strain. The constant ratio of shear stress to the rate of shear strain is called the coefficient of viscosity of the liquid. If this ratio is not constant then the liquid is non-Newtonian.

3. APPARATUS

3.1 Viscometers — Capillary type made of borosilicate glass, annealed suitable for this test are given in 3.1.1 to 3.1.3.

*Glossary of terms relating to bitumen and tar (*revised*).

IS : 1206 (Part II) - 1978

3.1.1 Cannon-Manning Vacuums Viscometer (Fig. 1) — The size numbers/approximate bulb factors *K*, and viscosity ranges for the series of Cannon-Manning Vacuum Capillary Viscometer are as follows:

Viscometer Size No.	Approximate Calibration Factor 30 cm Hg Vacuum Poises per s		Viscosity Range Poises	
	Bulb B	Bulb C		
10	2.0	0.6	36 to	800
11	6.0	2.0	120 to	2 400
12	20.0	6.0	360 to	8 000
13	60.0	20.0	1 200 to	24 000
14	200.0	60.0	3 600 to	80 000

For all viscometer sizes the volume of measuring bulb *C* is approximately three times that of bulb *B*. The viscosity ranges correspond to a filling time of 60 and 400 s for both measuring bulbs.

3.1.2 Asphalt Institute Vacuum Viscometer (Fig. 2) — The size numbers, approximate radii, approximate bulb factors *K*, and viscosity ranges for the series of Asphalt Institute Vacuum Capillary Viscometer are as follows:

Viscometer Size No.	Capillary Radius cm	Approximate Calibration Factor K. 30 cmHg. Vacuum: Poises per s			Viscosity Range Poises
		Bulb B	Bulb C	Bulb D	
25	0.012 5	2	1	0.7	42 to 800
50	0.025	8	4	3	180 to 3 200
100	0.050	32	16	10	600 to 12 800
200	0.100	128	64	40	2 400 to 52 000
400	0.200	500	250	160	9 600 to 200 000

This viscometer has measuring bulbs *B*, *C* and *D* located on the viscometer arm *M* which is a precision bore glass capillary. The measuring bulbs are 2 cm long capillary segments separated by timing marks *F*, *G*, *H* and *L*.

3.1.3 Modified Koppers Vacuum Viscometer (Fig. 3) — The size numbers approximate radii, approximate bulb factors *K*, and viscosity ranges for the series of Modified Koppers Vacuum Capillary Viscometer are as follows:

Viscometer Size No.	Capillary Radius cm	Approximate Calibration Factor K. 30cm Hg. Vacuum: Poises per s			Viscosity Range Poises
		Bulb B	Bulb C	Bulb D	
25	0.012 5	2	1	0.7	42 to 800
50	0.025	8	4	3	180 to 3 200
100	0.050	32	16	10	600 to 12 800
200	0.100	128	64	40	2 400 to 52 000
400	0.200	500	250	160	9 600 to 200 000

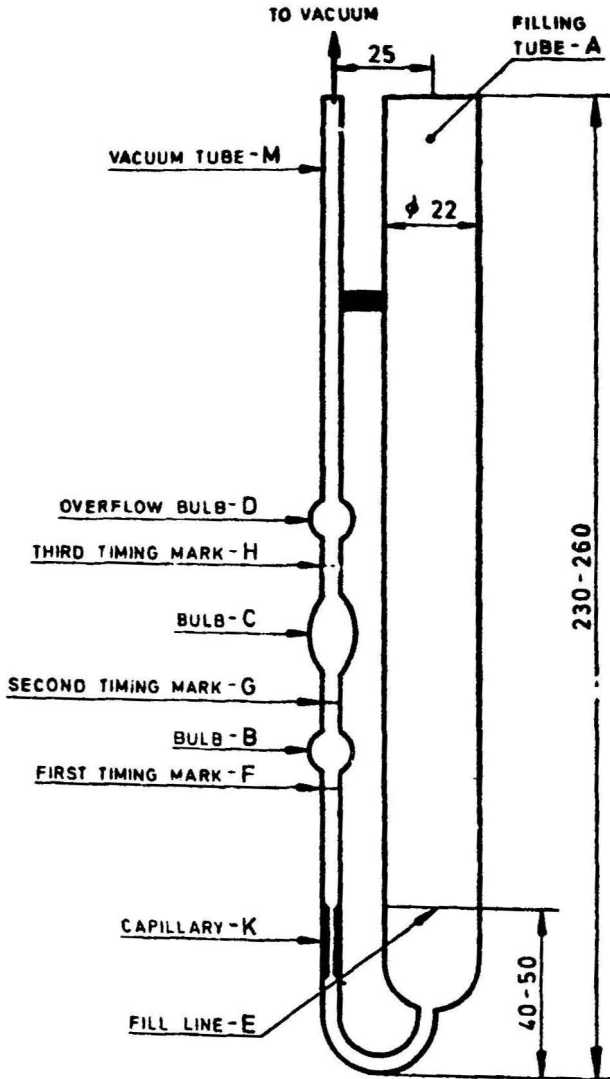

All dimensions in millimetres.

FIG. 1 CANNON-MANNING VACUUM CAPILLARY VISCOMETER

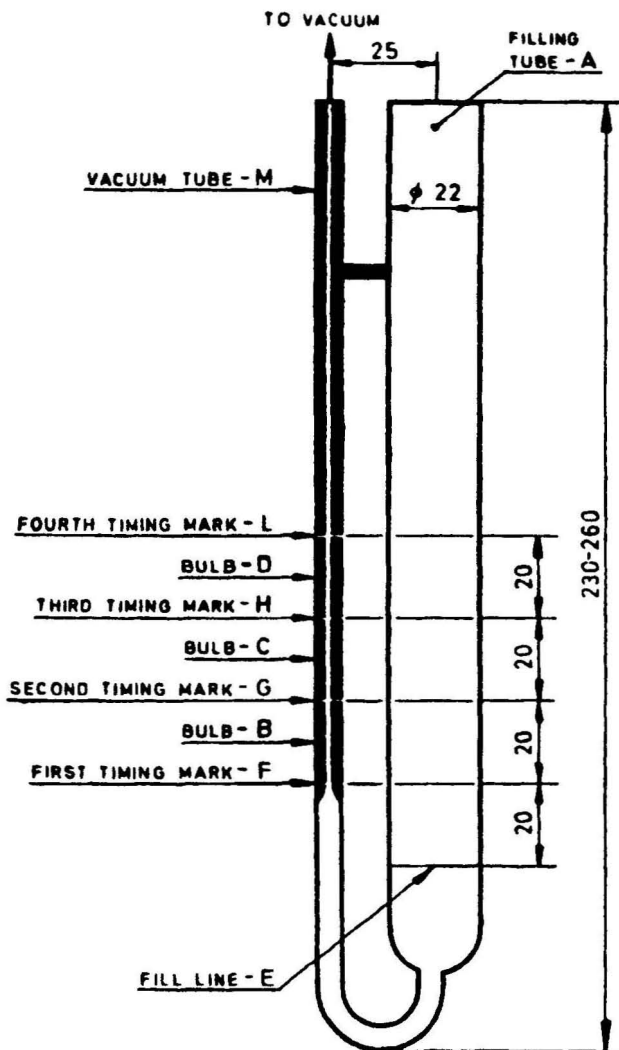

All dimensions in millimetres.

FIG. 2 ASPHALT INSTITUTE VACUUM CAPILLARY VISCOMETER

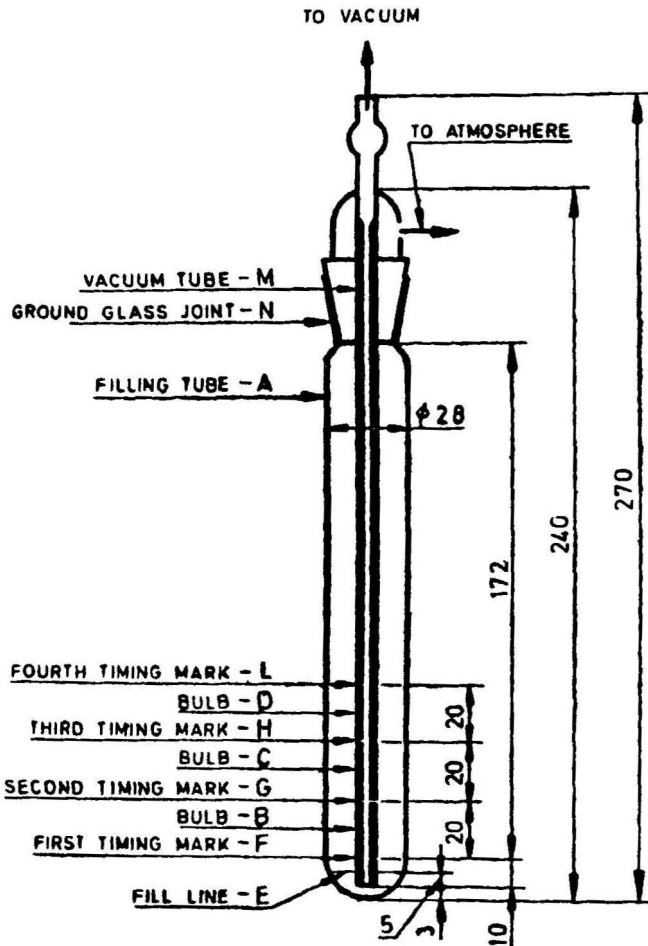

All dimensions in millimetres.

FIG. 3 MODIFIED KOPPERS VACUUM CAPILLARY VISCOMETER

This viscometer consists of a separate filling tube A, and a precision bore glass capillary vacuum tube M. These two parts are joined by borosilicate ground glass joint N, having a 24/40 standard taper. The measuring bulbs B, C, and D on the glass capillary are 2 cm capillary segments separated by timing marks F, G, H and L.

IS : 1206 (Part II) - 1978

A viscometer holder can be made by drilling a 28-mm hole through the centre of a No. 11 rubber stopper and setting the stopper between the hole and the edge. When placed in a 5-cm diameter hole in the bath cover, it holds the viscometer in place.

3.2 Thermometer — The thermometer shall be of mercury in glass tube with cylindrical bulbs and made of suitable thermometer glass and shall conform to the following requirements:

<i>Characteristic</i>	<i>Low</i>	<i>Medium</i>	<i>High</i>
Range	0 to 44°C	37.8 to 82°C	76 to 122°C
Graduations	0.2°C	0.2°C	0.2°C
Immersion	65 mm	65 mm	65 mm
Overall length	340 ± 10 mm	340 ± 10 mm	340 ± 10 mm
Stem diameter	5.5 to 8.0 mm	5.5 to 8.0 mm	5.5 to 8.0 mm
Bulb length	10 to 16 mm	10 to 16 mm	10 to 16 mm
Bulb diameter	Not larger than the stem diameter	Not larger than the stem diameter	Not larger than the stem diameter
Length of graduated portion	150 to 190 mm	150 to 190 mm	150 to 190 mm
Longer lines at each	1°C and 5°C	1°C and 5°C	1°C and 5°C
Figured at each	5°C	5°C	5°C
Scale	± 0.2°C	± 0.2°C	± 0.2°C

3.3 Bath — A suitable bath for immersion of the viscometer so that the liquid reservoir or top of the capillary, whichever is uppermost is at least 20 mm below the upper bath level, and with a provision for the visibility of the viscometer and the thermometer. Firm support for the viscometer shall be provided. The accuracy of the viscometer bath should be ± 0.1°C over the entire length of the viscometer or from viscometer to viscometer in the various bath positions.

3.4 Vacuum System — A vacuum system capable of maintaining a vacuum to within ± 0.05 cm of the desired level up to and including 30 cm of mercury. One such system is shown in Fig. 4. The glass tubing of 6.35 mm diameter and all glass joints should be completely airtight and no loss of vacuum should be permitted till the experiment is on. A vacuum or aspirator pump is suitable for the vacuum source.

3.5 Timing Device — A stop watch or stop clock capable of being read up to half a second.

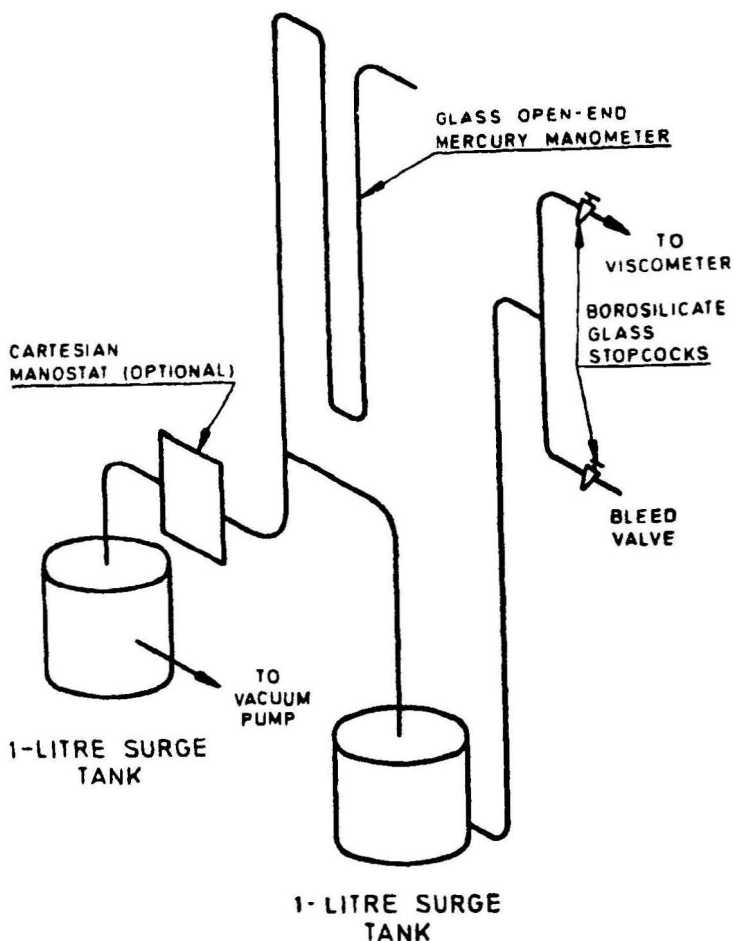

NOTE — All tubing is of glass with 6.35 mm OD.

FIG. 4 SUGGESTED VACUUM SYSTEM FOR VACUUM CAPILLARY VISCOMETERS

4. CALIBRATION OF VISCOMETERS

4.1 Reference Material — Any liquid of known viscosity may be used for calibration purposes.

4.2 Calibration — Charge a clean-dry viscometer by pouring the reference material to within ± 2 mm of fill line *E* (Fig. 1, 2 and 3). Place

IS : 1206 (Part II) - 1978

the charged viscometer in the viscometer bath maintained within $\pm 0.1^\circ\text{C}$ at the calibration temperature. Establish a 30 ± 0.05 cm vacuum in the vacuum system and connect it to the viscometer with valve closed in the line leading to the viscometer. After the viscometer has been in the bath for 30 ± 5 minutes, start the flow of liquid in the viscometer by opening the stop cock in the line leading to the vacuum system. Measure to within 0.5 s the time required for the leading edge of the meniscus to pass between timing marks *F* and *G*. Also measure to within 0.5 s the time required for the leading edge of the meniscus to pass between timing marks *G* and *H*. Calculate the calibration factor *K* for each bulb as follows:

$$K = \frac{V}{t}$$

where

K = viscometer bulb calibration factor poises/s at 30.0 cm Hg,

V = absolute viscosity of reference material at calibration temperature in poises, and

t = flow time in seconds.

Repeat the calibration procedure using the same viscosity standard or another reference material. Record the average calibration constant *K*.

4.2.1 The duplicate determination of calibration constant *K* for each bulb shall be within 2 percent of the mean value. The value of viscometer constants shall be expressed to the nearest 0.1 percent.

5. PROCEDURE

5.1 **Preparation of the Sample** — Heat the sample to a temperature not more than 60°C for the tars and pitches and not more than 90°C for bitumens above their respective approximate softening point temperature respectively until it has become sufficiently fluid to pour. Transfer about 20 ml into a suitable container and maintain it to a temperature of $135 \pm 5.5^\circ\text{C}$ stirring occasionally to prevent local overheating and allow the entrapped air to escape.

5.1.1 Charge the viscometer by pouring the prepared sample to within ± 2 mm of fill line *E*. Place the charged viscometer in an oven or bath maintained at $135 \pm 5.5^\circ\text{C}$ for a period of 10 ± 2 min to allow large air bubbles to escape.

5.2 **Testing** — Maintain the bath at the test temperature within $\pm 0.1^\circ\text{C}$. Place the charged viscometer vertically in the waterbath with the help of a holder so that the uppermost timing mark is at least 2 cm

below the surface of the bath liquid. Establish a vacuum of 30 ± 0.05 cm of mercury in the vacuum system and connect it to the viscometer with the valve closed. After the viscometer has remained in the bath for 30 ± 5 min open the valve and allow the asphalt to flow into the viscometer. Measure to within ± 0.5 s the time required for the leading edge of the meniscus to pass between successive pairs of timing marks. Upon completion of the test, remove the viscometer from the bath and place it in an inverted position in an oven maintained at $135 \pm 5^\circ\text{C}$ until asphalt is drained off thoroughly from the viscometer. Clean the viscometer thoroughly by rinsing several times with an appropriate solvent completely. Dry the tube by passing a slow stream of filtered dry air through the capillary for 2 minutes. Periodically clean the instrument with chromic acid to remove organic deposits. Rinse thoroughly with distilled water and acetone and dry with clean air.

6. CALCULATION

6.1 Calculate and report the absolute viscosity to three significant figures, by the following equation:

$$\text{Viscosity Poises} = Kt$$

where

K = selected calibration factor, in poise per second; and

t = flow time, in seconds.

6.2 Always report the test temperature and vacuum with the viscosity test results. For example, viscosity at 60°C , 30 cmHg Vacuum in poises.

7. PRECISION

7.1 The duplicate test results should not differ by more than the following:

Repeatability
7 percent of their mean

Reproducibility
10 percent of their mean

As in the Original Standard, this Page is Intentionally Left Blank

Indian Standard
METHODS FOR TESTING
TAR AND BITUMINOUS MATERIALS:
DETERMINATION OF VISCOSITY

PART III KINEMATIC VISCOSITY

(*First Revision*)

(Incorporating Amendment No. 1)

1. SCOPE

1.1 This standard (Part III) covers the method for the determination of kinematic viscosity of paving grade and cut-back bitumens and distillation residues of cut-backs. It is applicable to the materials having a viscosity range of 30-100 000 cSt.

2. TERMINOLOGY

2.0 For the purpose of this standard, the following definitions and those given in IS : 334-1965* shall apply.

2.1 **Absolute or Dynamic Viscosity of a Newtonian Liquid** — It is an internal friction such that, if a tangential force of one dyne (0.000 01 N) acting on planes of unit area separated by unit distance of the liquid produces unit tangential velocity, the cgs unit of the viscosity for the liquid is 1 Poise.

2.2 **Density** — It is the mass per unit volume, the cgs unit of density is g/cm^3 and the SI unit of density is 1 kg/m^3 .

2.3 **Kinematic Viscosity of a Newtonian Liquid** — It may be defined as the quotient of the absolute or dynamic viscosity divided by the density of the liquid under test; both at the same temperature. The cgs unit of kinematic viscosity is the stoke which has the dimensions square centimetre per second. For petroleum products the kinematic viscosity is generally expressed in centistokes (cSt) which is 1/100th of a stoke.

2.4 **Newtonian Liquid** — A liquid in which the shear stress is directly proportional to the rate of shear strain. The constant ratio of shear stress to the rate of shear strain is called the coefficient viscosity of the liquid. If this ratio is not constant then the liquid is non-Newtonian.

*Glossary of terms relating to bitumen and tar (*revised*).

3. APPARATUS

3.1 Viscometers — The capillary type of viscometer of borosilicate glass annealed suitable for the test are as given in 3.1.1 and 3.1.2.

3.1.1 Cannon-Fenske Viscometer for Opaque Liquids — Detailed drawings of the reverse-flow Cannon-Fenske viscometer are given in Fig. 1. The size, dimensions, approximate constant, kinematic viscosity range, capillary diameter and bulb, volumes shall be as given in Table 1.

TABLE 1 DIMENSIONS OF CANNON-FENSKE OPAQUE VISCOMETER FOR OPAQUE AND TRANSPARENT LIQUIDS

SIZE NO.	APPROXIMATE CONSTANT, CST/S	KINEMATIC VISCOSITY RANGE, CST	INSIDE DIA OF TUBE, R, mm ($\pm 2\%$)	INSIDE DIA OF TUBE, N AND G, TUBES E, F AND K mm ($\pm 5\%$)	VOLUME BULBS A, C AND J ml ($\pm 5\%$)	VOLUME BULB D ml ($\pm 5\%$)
150	0.035	2.1 to 35	0.78	3.2	2.1	11
200	0.1	6 to 100	1.02	3.2	2.1	11
300	0.25	15 to 200	1.26	3.4	2.1	11
350	0.5	30 to 500	1.48	3.4	2.1	11
400	1.2	72 to 1 200	1.88	3.4	2.1	11
450	2.5	150 to 2 500	2.20	3.7	2.1	11
500	8	480 to 8 000	3.10	4.0	2.1	11
600	20	1 200 to 20 000	4.00	4.7	2.1	13

3.1.2 BS U-Tube Modified Reverse Flow Viscometer — The viscometer shall be made of clear borosilicate or other heat resistant glass free from visible defects. All glass tubing used in the construction of a single viscometer shall be of the same composition and the finished instrument shall be thoroughly annealed. The design and dimensions of the viscometer are given in Fig. 2 and Table 2.

TABLE 2 DIMENSIONS AND VISCOSITY RANGES OF BS U-TUBE, MODIFIED REVERSE FLOW VISCOMETER FOR OPAQUE LIQUID

SIZE NO.	APPROXIMATE CONSTANT, CST/S	VISCOSITY RANGE, CST	INSIDE DIA OF TUBE R, mm ($\pm 2\%$)	LENGTH OF THE TUBE R, mm	INSIDE DIA AT E, F AND G, mm	VOLUME BULB C ml ($\pm 5\%$)
4	0.1	6-100	1.26	185	3.0-3.3	4.0
5	0.3	18-300	1.64	185	3.0-3.3	4.0
6	1.0	60-1 000	2.24	185	3.0-3.3	4.0
7	3.0	180-3 000	2.93	185	3.3-3.6	4.0
8	10	600-10 000	4.00	185	4.4-4.8	4.0
9	30	1 800-30 000	5.5	185	6.0-6.7	4.0
10	100	6 000-100 000	7.70	210	7.7	4.0
11	300	18 000-300 000	10.00	210	10.00	4.0

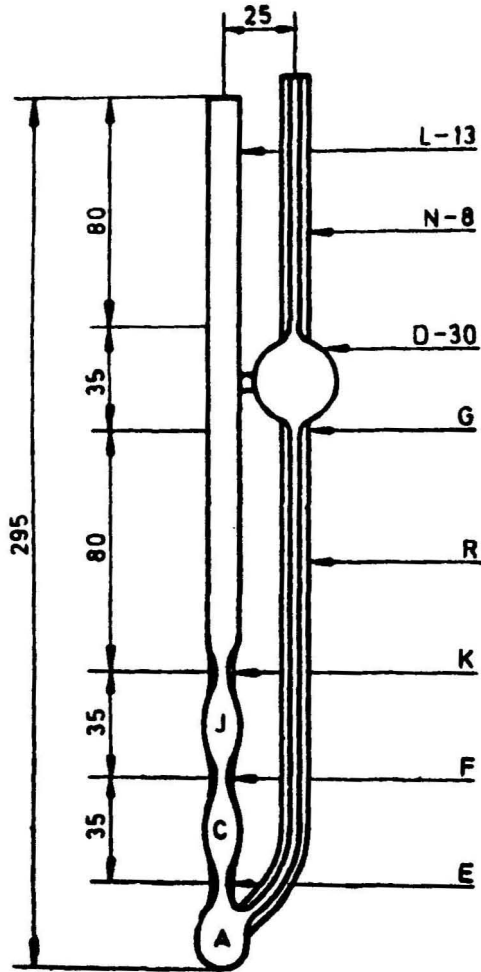

All dimensions in millimetres.

FIG. 1 CANNON-FENSKE OPAQUE VISCOMETER FOR OPAQUE AND TRANSPARENT LIQUIDS

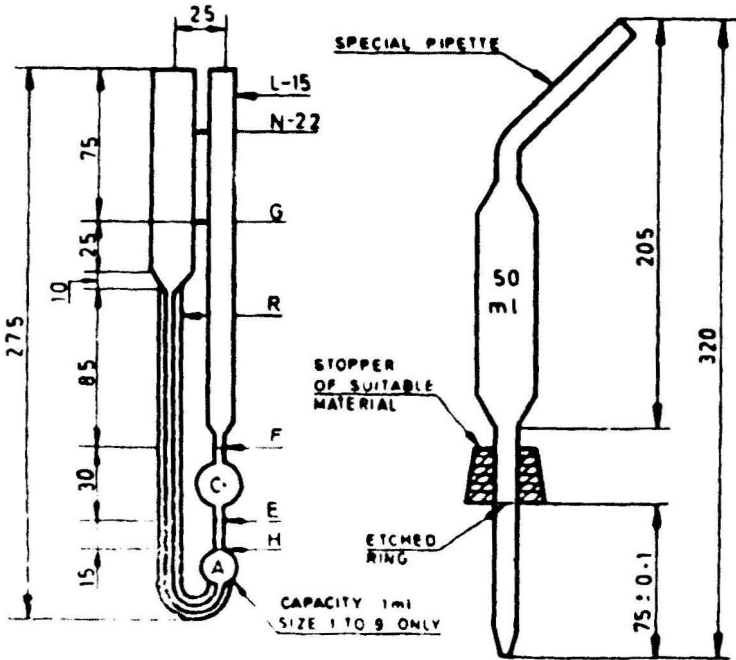

All dimensions in millimetres

FIG. 2 BS/IP/RF U-TUBE REVERSE FLOW VISCOMETER FOR OPAQUE LIQUIDS

3.2 Bath — A suitable bath for immersion of the viscometer so that the liquid reservoir or top of the capillary whichever is uppermost is at least 20 mm below the upper bath level. Provision shall be there for visibility of the viscometer and the thermometer. The efficiency of the stirring and the balance between heat losses and heat input shall be such that the temperature of the bath medium is maintained at $\pm 0.1^\circ\text{C}$ over the entire length of the viscometer.

3.3 Thermometers — The thermometers shall be of mercury in glass tube with cylindrical bulbs and made of suitable thermometer glass and shall conform to the following requirements:

Characteristic	Low	Medium	High
Range	0 to 44°C	37.8 to 82°C	76 to 122°C
Graduations	0.2°C	0.2°C	0.2°C
Immersion	65 mm	65 mm	65 mm

Characteristic	Low	Medium	High
Overall length	340 ± 10 mm	340 ± 10 mm	340 ± 10 mm
Stem diameter	5.5 to 8.0 mm	5.5 to 8.0 mm	5.5 to 8.0 mm
Bulb length	10 to 16 mm	10 to 16 mm	10 to 16 mm
Bulb diameter	Not larger than the stem diameter	Not larger than the stem diameter	Not larger than the stem diameter
Length of graduated portion	150 to 190 mm	150 to 190 mm	150 to 190 mm
Longer lines at each, figured at each	1°C and 5°C	1°C and 5°C	1°C and 5°C
Scale	± 0.1°C	± 0.1°C	± 0.1°C

3.4 Timing Device — Any timing device such as stop-watch or stop-clock capable of being read up to 0.5 s.

4. CALIBRATION OF VISCOMETER

4.1 Reference Material — Any liquid of known viscosity may be used for calibration purposes.

4.2 Calibration — Charge the clean dry viscometer by pouring the reference material. Place the charged viscometer in the viscometer bath maintained at calibration temperature within ± 0.1°C. Allow the charged viscometer to remain in the bath long enough to reach the test temperature. Measure to within 0.1 s the time required for the leading edge of the meniscus to pass from the first timing mark to the second. Calculate the viscometer constant C , as follows:

$$C = \frac{V}{t}$$

where

V = viscosity in centistokes for the standard liquid, and
 t = efflux time in seconds.

4.2.1 The duplicate determination of calibration constant K for each bulb shall be within 2 percent of the mean value. The value of Viscometer constants shall be expressed to the nearest 0.1 percent.

4.3 If the viscometer is used at a location other than the calibrating laboratory the constant C should be corrected for the difference in the acceleration of gravity 'g' at the two locations as follows:

$$C_2 = \frac{g_2}{g_1} \times C_1$$

IS : 1206 (Part III) - 1978

where

C_2 = calibration constant in the testing laboratory,

C_1 = calibration constant in the calibration laboratory,

g_2 = acceleration of gravity at the testing laboratory, and

g_1 = acceleration of gravity at the calibration laboratory.

5. PREPARATION OF SAMPLE

5.1 Procedure for Cut-Back Bitumens and Oil Distillates —

Open the sample container and mix the sample thoroughly by stirring for 30 s taking care to avoid entrapped air. For too viscous samples, heat the sealed container in a bath or oven maintained at about 60°C. Pour immediately 20 ml into a clean dry container having a capacity of about 30 ml and seal the container immediately.

5.2 Procedure for Bitumens —

Heat the sample to a temperature not more than 60°C for tars and pitches and not more than 90% for bitumens above the corresponding approximate softening point temperature respectively until it attains pouring consistency. Stir it thoroughly and transfer approximately 20 ml in a 30 ml container. Local over-heating and entrapped air should be avoided.

6. PROCEDURE

6.1 Procedure for Cannon-Fenske Viscometer

6.1.1 To charge the Cannon-Fenske viscometer invert the viscometer and apply suction to the tube L , immersing tube N in the liquid sample. Draw liquid through tube N filling bulbs D to fill mark G , wipe excess sample off tube N and invert the viscometer to its normal position. Align the viscometer vertically in the bath. Visual observation is sufficient. However, it can be done more accurately and quickly by suspending a plumb bulb in the tube L . Allow the viscometer to remain in the constant temperature bath for a sufficient time to ensure that the sample reaches temperature equilibrium. It takes about 20 min at 38°C, 25 min at 100°C and 30 min at 135°C. When the test temperature is reached, remove the stopper in the tubes N and L respectively and allow the sample to flow by gravity. Measure to the nearest 0.1 s the time required for the leading edge of the meniscus to pass from timing mark E to timing mark F . If this efflux time is less than 60 s, select a viscometer of smaller capillary diameter and repeat the operation.

6.1.2 Upon completion of the test, clean the viscometer thoroughly by several rinsings with an appropriate solvent completely miscible with the sample, followed by a completely volatile solvent. Dry the tube by passing a slow stream of filtered dried air through the capillary for 2 min or until last trace of solvent is removed.

6.2 Procedure for BS U-Tube Modified Reverse Flow Viscometer

6.2.1 Mount the BS U-tube viscometer in the constant temperature bath keeping tube *L* vertical. Pour sample through tube *N* to a point just above filling mark *G*, allow the sample to flow freely through capillary *R*, taking care that the liquid column remains unbroken until the lower mark *H* and then arrest its flow by closing the timing tube with a cork or rubber stopper in tube *L*. Add more liquid, if necessary to bring the upper meniscus slightly above mark *G*. After allowing the sample to attain bath temperature and any air bubble to rise to the surface (usually about 20-30 min is required), gently loosen the stopper allowing the sample to flow until it is approximately at the lower filling mark *H* and press back the stopper to arrest flow. Remove the excess sample above filling mark *G* by inserting the special pipette until its cork rests on top of the tube *N* and apply gentle suction until air is drawn through. The upper meniscus shall coincide with mark *G*. Allow the viscometer to remain in the constant temperature bath for a sufficient time to ensure that the sample reaches temperature equilibrium. It takes about 20 min at 38°C, 25 min at 100°C and 30 min at 135°C. Remove the stopper in the tube *N* and *L* respectively and allow the sample to flow by gravity. Measure to the nearest 0.1 s the time required for the leading edge of the meniscus to pass from timing mark *E* to timing mark *F*. If this efflux time is less than 60 s, select a viscometer of smaller capillary diameter and repeat the operation.

6.2.2 Upon completion of the test, clean the viscometer thoroughly by several mixing with an appropriate solvent completely miscible with the sample followed by a completely volatile solvent. Dry the tube by passing slow stream of filtered dry air through the capillary until the last trace of solvent is removed.

7. CALCULATION

7.1 Calculate the kinematic viscosity up to three significant figures with the help of following equation:

$$\text{Kinematic viscosity } \nu = Ct$$

where

C = calibration constant of the viscometer in centistokes per second, and

t = efflux time in seconds.

IS : 1206 (Part III) - 1978

8. REPORT

8.1 Report always the test temperature along with the results as follows:

Kinematic viscosity
at 60°C = 'x' cSt

9. PRECISION

9.1 The duplicate test results should not differ by more than the values given in Table 3.

TABLE 3 PRECISION OF TEST RESULTS

SL NO.	MATERIAL	REPEATABILITY	REPRODUCIBILITY
(1)	(2)	(3)	(4)
		% of Mean	% of Mean
i)	Asphaltic bitumen at 135°C	1.8	8.8
ii)	Cutback bitumens at 60°C		
	a) Below 3 000 cSt	1.5	3
	b) 3 000 to 6 000 cSt	2.0	9.9
	c) Above 6 000 cSt	8.9	10.0

Indian Standard
**METHODS FOR TESTING
TAR AND BITUMINOUS MATERIALS:
DETERMINATION OF EQUIVISCIOUS
TEMPERATURE (EVT)**
(First Revision)

1. SCOPE

1.1 This standard covers the method for the determination of equiviscous temperature (EVT) of road tar.

2. TERMINOLOGY

2.0 For the purpose of this standard, the following definition and those given in IS : 334-1965* shall apply.

2.1 **Equiviscous Temperature** — That temperature in degrees centigrade at which the viscosity of the tar or pitch is 50 seconds as measured by standard tar viscometer specified in IS : 1206 (Part I)- 1978†.

3. APPARATUS

3.1 The tar viscometer and accessories as specified under 3.1.1 of IS : 1206 (Part I)-1978† shall be used.

4. PROCEDURE

4.1 The viscosity at any specified temperature preferably a multiple of 5°C shall be determined in the same manner as specified in Method A : Determination of viscosity of road tars [see IS : 1206 (Part I)-1978†] shall be followed.

5. CALCULATION

5.1 Determine the viscosity of the road tar by Method A of IS : 1206 (Part I)-1978† using the 10-mm tar cup at the given temperature.

*Glossary of terms relating to bitumen and tar (*revised*).

†Methods for testing tar and bituminous materials: Determination of viscosity : Part I Industrial viscosity (*first revision*).

IS : 1207 - 1978

5.1.1 From the viscosity so determined and the temperature of test, calculate the EVT from Table 1, which shows the corrections to be applied for the temperature of test to give the EVT when the viscosity has been determined using the 10-mm cup.

Example: For a tar having a viscosity of 106 seconds at 30°C, the correction is given in the row against 100 and col 6 as being + 4.3. Therefore, its EVT shall be 34.3°C.

TABLE 1 CORRECTION IN CENTIGRADE DEGREES TO BE APPLIED TO TEMPERATURES OF TEST TO GIVE EVT OF TAR OF KNOWN VISCOSITY DETERMINED BY USING THE SPECIFIED 10-mm CUP

(Clauses 5.1.1, 5.1.2 and 5.2)

VISCO-SITY IN SECONDS	CORRECTION IN °C										
	0	1	2	3	4	5	6	7	8	9	
10	-10.4	-9.8	-9.2	-8.7	-8.2	-7.7	-7.3	-6.9	-6.5	-6.1	
20	-5.7	-5.4	-5.1	-4.8	-4.5	-4.3	-4.0	-3.8	-3.5	-3.3	
30	-3.1	-2.9	-2.7	-2.5	-2.3	-2.2	-2.0	-1.9	-1.7	-1.5	
40	-1.4	-1.2	-1.1	-0.9	-0.8	-0.6	-0.5	-0.4	-0.3	-0.1	
50	+0.0	+0.1	+0.2	+0.3	+0.5	+0.6	+0.7	+0.8	+0.9	+1.0	
60	+1.1	+1.2	+1.3	+1.4	+1.5	+1.6	+1.7	+1.7	+1.8	+1.9	
70	+2.0	+2.1	+2.2	+2.2	+2.3	+2.4	+2.5	+2.5	+2.6	+2.7	
80	+2.8	+2.8	+2.9	+3.0	+3.0	+3.1	+3.1	+3.2	+3.3	+3.3	
90	+3.4	+3.5	+3.5	+3.6	+3.6	+3.7	+3.7	+3.8	+3.9	+3.9	
100	+4.0	+4.0	+4.1	+4.1	+4.2	+4.2	+4.3	+4.3	+4.4	+4.4	
110	+4.5	+4.6	+4.6	+4.7	+4.7	+4.8	+4.8	+4.9	+4.9	+5.0	
120	+5.0	+5.1	+5.1	+5.2	+5.2	+5.2	+5.3	+5.3	+5.4	+5.4	
130	+5.5	+5.5	+5.5	+5.6	+5.6	+5.7	+5.7	+5.7	+5.8	+5.8	
140	+5.9	+5.9	+6.0	+6.0	+6.0	+6.1	+6.1	+6.1	+6.2	+6.2	

5.1.2 If the viscosity obtained is below 33 seconds or above 75 seconds, ascertain the approximate EVT from Table 1. Repeat the determination of the viscosity at the centigrade temperature, nearest to the approximate EVT, which is a multiple of 5. From the viscosity obtained in this repeat determination and the temperature of this test, calculate EVT from Table 1.

5.1.2.1 The results of repeat determinations on portions of the same tar sample shall fall within $\pm 0.2^\circ\text{C}$ of the average of several readings.

The following example illustrates the procedure when a retest is necessary:

A tar tested at 35°C is found to have a viscosity of 92 seconds, which is outside the permissible range of 33 to 75 seconds. Table 1 gives a correction of +3.5°C to be applied, making the EVT approximately 38.5°C. The determination of the viscosity is, therefore, repeated at the temperature nearest to 38.5°C which is a multiple of 5, that is at 40°C. At this temperature the viscosity is found to be 38 seconds. From Table 1, it is found that a correction of -1.7°C is to be applied to the temperature of test. The EVT is, therefore $(40 - 1.7)^\circ\text{C} = 38.3^\circ\text{C}$.

5.2 Method for Determining True EVT — The EVT determined as described in 5.1 may differ from the true EVT. In the case of tars of EVT at or above 17.5°C, the EVT determined according to the method described may differ from the true EVT by an amount in general not exceeding 10 percent of the difference between the temperature of test and the EVT. If it be required to know the true EVT, the viscosity shall be determined at two temperatures, differing by at least 5°C but not more than 10°C and such that the viscosities are within the range of 25 to 100 seconds. The value of the EVT is calculated for each temperature of test by reference to Table 1. If the two values are not identical, the true EVT shall be calculated by means of the following formula:

$$\text{True EVT} = T_1 - \frac{d_1}{(d_2 - d_1)} \times (T_2 - T_1)$$

where

T_1 and T_2 = values of the EVT calculated from the two test temperatures, and

d_1 and d_2 = respective corrections applied to the temperatures of test to give the EVT.

Care shall be taken with the signs for d_1 and d_2 : if the temperature of the test be above the EVT, the correction shall be negative. If the same value be obtained, it represents the true EVT.

5.3 Approximate Relationship Between EVT and Viscosity

5.3.1 The EVT-Viscosity chart (*see* Fig. 1) shows the approximate relationship ranging between EVT and viscosity at various temperatures from 20 to 60°C. To obtain from a given EVT the equivalent viscosity in seconds at any one of the test temperatures shown, a straight-edge shall be laid at right angles across the scale and the reading made on the appropriate viscosity scale.

5.3.2 Since viscosities within 10 to 140 seconds only may legitimately be determined on the tar viscometer described in Method A of

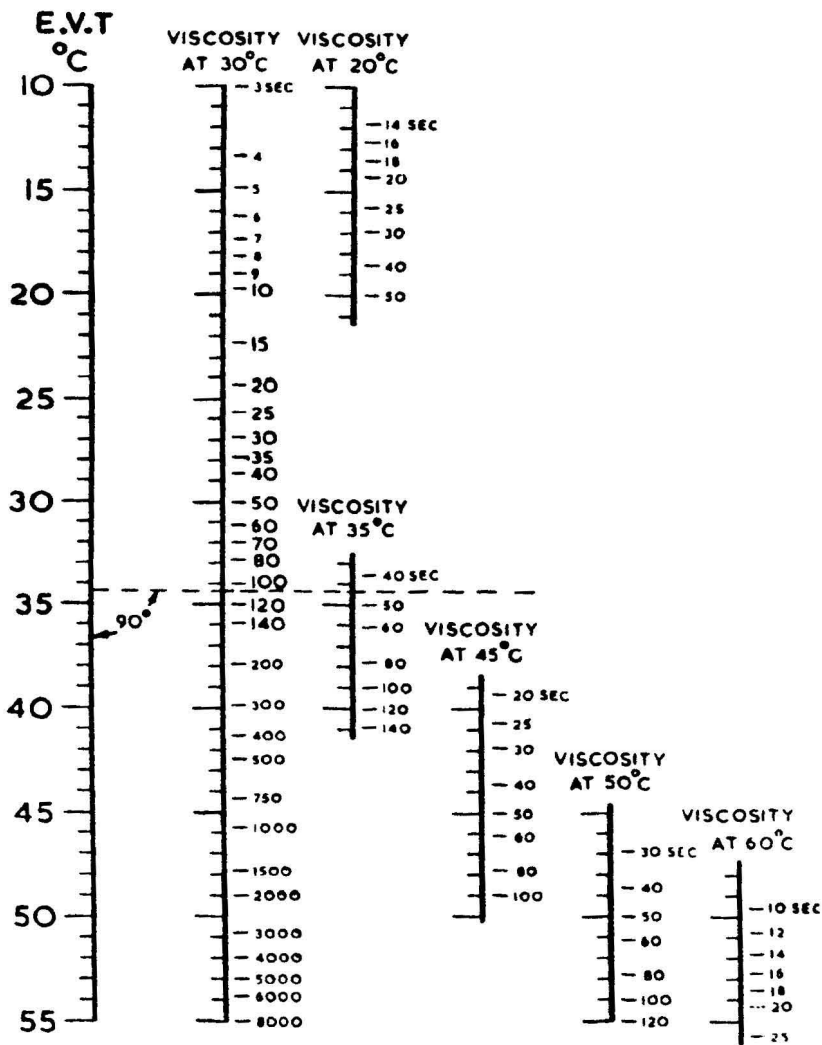

FIG. 1 EVT-VISCOSITY RELATIONSHIP CHART

IS : 1206 (Part I)-1978* figures outside these limits given in the chart are meant to be used for the purpose of rough comparison and not for accurate evaluation.

6. REPORT

6.1 The report of the EVT shall be the temperature in degrees centigrade at which the viscosity is 50 seconds as measured by the standard tar viscometer.

7. PRECISION

7.1 The EVT determination made by different operators should not differ by more than the following:

Repeatability
0.4°C

Reproducibility
0.7°C

*Methods for testing tar and bituminous materials: Determination of viscosity: Part I Industrial viscosity (*first revision*).

As in the Original Standard, this Page is Intentionally Left Blank

Indian Standard

METHODS FOR TESTING
TAR AND BITUMINOUS MATERIALS:
DETERMINATION OF DUCTILITY

(First Revision)

(Incorporating Amendment No. 1)

1. SCOPE

1.1 This standard covers the method of determination of ductility of distillation residue of cutback bitumen, blown type bitumen and other bituminous products.

2. TERMINOLOGY

2.0 For the purpose of this standard the following definition and those given in IS : 334-1965* shall apply.

2.1 **Ductility** — The ductility of a bituminous material is measured by the distance in centimetres to which it will elongate before breaking when a briquette specimen of the material of the form described under 3.1 are pulled apart at a specified speed and at a specified temperature.

3. APPARATUS

3.1 **Mould** — made of brass with the shape, dimensions and tolerances as shown in Fig. 1. The ends *b* and *b'* are known as clips, and the parts *a* and *a'* as sides of the mould. The dimensions of the mould shall be such that when properly assembled, it will form a briquette specimen having the following dimensions:

Total length	75.0 ± 0.5 mm
Distance between clips	30.0 ± 0.3 mm
Width at mouth of clip	20.0 ± 0.2 mm
Width at minimum cross-section (half way between clips)	10.0 ± 0.1 mm
Thickness throughout	10.0 ± 0.1 mm

*Glossary of terms relating to bitumen and tar (*revised*).

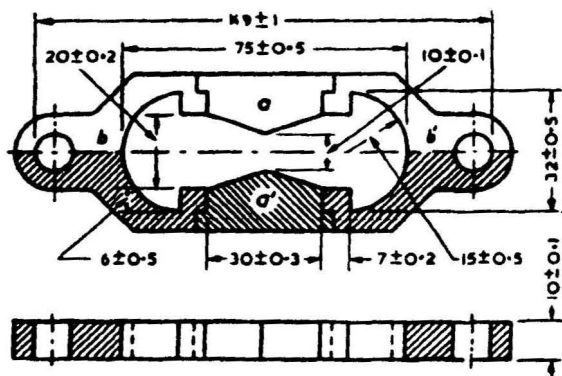

All dimension in millimetres.

FIG. 1 MOULD FOR DUCTILITY TEST

3.2 Water Bath — A bath preferably with a thermostat maintained within $\pm 0.1^\circ\text{C}$ of the specified test temperature, containing not less than 10 litres of water, the specimen being immersed to a depth of not less than 100 mm and supported on a perforated shelf not less than 50 mm from the bottom of the bath.

3.3 Testing Machine — For pulling the briquette of bituminous material apart, any apparatus may be used which is so constructed that the specimen will be continuously immersed in water as specified under 4.3 while the two clips are pulled apart horizontally with minimum vibrations at a uniform speed, as specified and with suitable arrangement for stirring the water for attaining uniformity in temperature.

3.4 Thermometer — conforming to the following requirements:

<i>Characteristic</i>	<i>Requirement</i>
Range	0 to 44°C
Graduations	0.2°C
Immersion	65 mm
Overall length	340 ± 10 mm
Stem diameter	5.5 to 8.0 mm
Bulb length	10 to 16 mm
Bulb diameter	Not larger than stem diameter
Length of graduated portion	150 to 190 mm
Longer lines at each	1°C and 5°C
Figured at each	5°C
Scale	$\pm 0.2^\circ\text{C}$

4. PROCEDURE

4.1 Unless otherwise specified, the test shall be conducted at a temperature of $25.0 \pm 0.5^\circ\text{C}$ and at a rate of pull of 50.0 ± 2.5 mm/min.

4.1.1 When a low temperature ductility test is desired, the test shall be made at a temperature of $4.0 \pm 0.5^\circ\text{C}$ and at a rate of pull of 10.0 ± 0.5 mm/min.

4.2 Completely melt the bituminous material to be tested to a temperature of 75 to 100°C above the approximately softening point until it becomes thoroughly fluid. Assemble the mould on a brass plate and in order to prevent the material under test from sticking, thoroughly coat the surface of the plate and interior surfaces of the sides of the mould (α and α' in Fig. 1) with a mixture of equal parts of glycerine and dextrine. In filling, pour the material in a thin stream back and forth from end to end of the mould until it is more than level full. Leave it to cool at the room temperature for 30 to 40 min, and then place in a water bath maintained at the specified temperature for 30 min after which cut off the excess bitumen by means of a hot, straight-edged putty knife or spatula so that the mould shall be just level full.

4.3 **Testing** — Place the brass plate and mould with briquette specimen, in the water bath and keep at the specified temperature for about 85 to 95 minutes. Then remove the briquette from the plate, detach the side pieces, and test the briquette immediately.

4.3.1 Attach the rings at each end of the clips to the pins or hooks in the resting machine and pull the two clips apart horizontally at a uniform speed as specified until the briquette ruptures. Measure the distance in centimetres through which the clips have been pulled to produce rupture. While the test is being made, make sure that the water in the tank of the testing machine covers the specimen both above and below it by at least 25 mm and is maintained continuously within $\pm 0.5^\circ\text{C}$ of the specified temperature.

5. REPORT

5.1 A normal test is one in which the material between the two clips pulls out to a point or to a thread and rupture occurs where the cross-sectional area is a minimum. Report the average of three normal tests as the ductility of the sample, provided the three determinations be within ± 5 percent of their mean value.

5.1.1 If the value of three determinations do not lie within ± 5 percent of their mean but the two higher values are within ± 5 percent of their mean then record the mean of the two higher values as test result.

IS : 1208 - 1978

5.2 If the bituminous material comes in contact with the surface of the water or the bottom of the bath, the test shall not be considered normal. Adjust the specific gravity of the water in the bath by the addition of either methyl alcohol or sodium chloride so that the bituminous material does not either come to the surface of the water, or touch the bottom of the bath at any time during the test.

5.3 If a normal test is not obtainable on three successive tests, report the ductility as being unobtainable under the conditions of test.

6. PRECISION

6.1 Test results shall not differ by more than the following:

Repeatability	10 percent of the mean
Reproducibility	20 percent of the mean

7. PRECAUTIONS

7.1 The plate upon which the mould is placed shall be perfectly flat and level so that the bottom surface of the mould touches it throughout.

7.2 In filling the mould, care shall be taken not to disarrange the parts and thus distort the briquette and to see that no air pocket shall be within the moulded sample.

Indian Standard
**METHODS FOR TESTING
TAR AND BITUMINOUS MATERIALS:
DETERMINATION OF FLASH POINT
AND FIRE POINT
(*First Revision*)**

1. SCOPE

1.1 This standard covers the methods for the determination of flash point and fire point of asphaltic bitumen and fluxed native asphalt, cutback bitumen and blown type bitumen.

2. TERMINOLOGY

2.0 For the purpose of this standard, the following definitions and those given in IS : 334-1965* shall apply.

2.1 **Flash Point** — The flash point of a material is the lowest temperature at which the application of test flame causes the vapours from the material momentarily catch fire in the form of a flash under specified conditions of test.

2.2 **Fire Point** — The fire point is the lowest temperature at which the application of test flame causes the material to ignite and burn at least for 5 s under specified conditions of test.

**3. METHOD A (PENSKY-MARTENS — CLOSED), FOR
DETERMINATION OF FLASH POINT FOR BITUMEN
OTHER THAN CUTBACK BITUMEN**

3.1 Apparatus

3.1.1 Pensky-Martens Closed Tester (see Fig. 1) consisting of the following major parts:

- a) *Cup* — made of brass, conforming to the dimensions given in Table 1. The inside of the cup may be turned to a slightly larger diameter above the filling mark and the outside may be tapered above the flange, but the wall thickness at the upper edge shall

*Glossary of terms relating to bitumen and tar (*revised*).

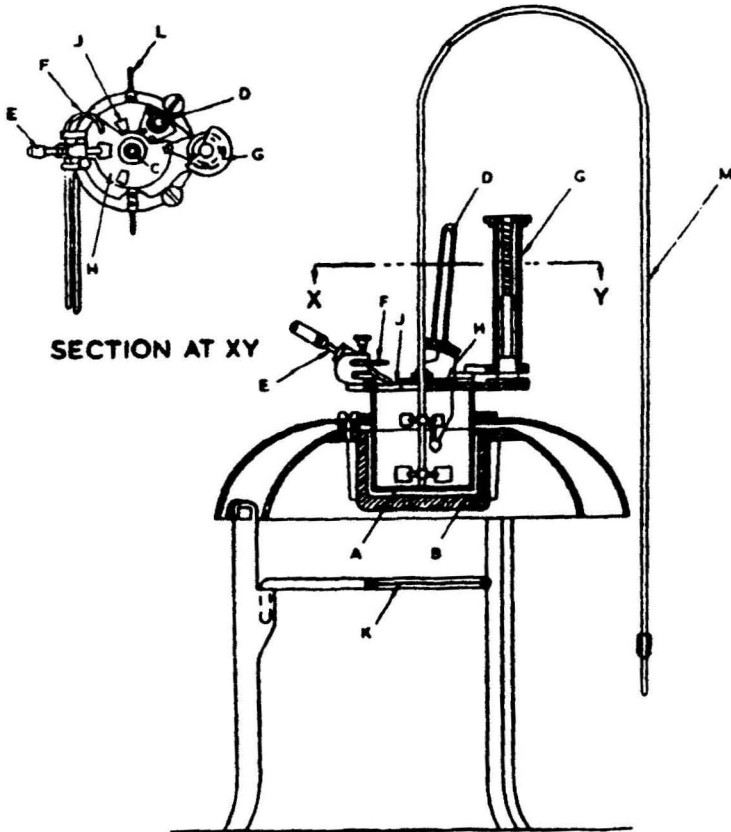

- | | |
|---------------------|-----------------------|
| A — Oil-Cup | H — Revolving Shutter |
| B — Heating Vessel | J — Orifice |
| C — Stirrer | K — Gauge Disc |
| D — Thermometer | L — Lifting Hooks |
| E — Ignition Burner | M — Optional Form of |
| F — Pilot Burner | Stirrer Operating |
| G — Spring Handle | Device |

FIG. 1 PENSKY-MARTENS CLOSED TESTER

**TABLE 1 DIMENSIONAL REQUIREMENTS OF PENSKY-MARTENS
FLASH TESTER**

[Clause 3.1.1 (a)]

Sl No.	DIMENSIONAL REQUIREMENTS	Min mm	Normal mm	Max mm
(1)	(2)	(3)	(4)	(5)
i)	Inside diameter below filling mark	49.5	50.8	52.1
ii)	Difference between inside and outside diameters below filling mark	3.0	3.2	3.4
iii)	Inside height	54.6	55.9	57.2
iv)	Thickness of bottom	1.8	2.4	3.0
v)	Distance from rim to filling mark	21.5	21.8	22.2
vi)	Distance, lower surface flange to bottom of cup	45.2	45.6	46.0

be not less than one millimetre. The flange should be approximately 12 mm in width and approximately 3 mm in thickness. It shall be equipped with devices for locating the position of the lid on the cup and the cup itself in the stove. A handle, attached permanently to the flange of the cup, is a desirable accessory.

b) *Lid* — The lid, including (1) stirring device, (2) cover proper, (3) shutter, and (4) flame-exposure device, shall satisfy the following requirements:

1) *Stirring device* — The lid shall be equipped with a stirring device consisting of a vertical steel shaft, neither less than 2.5 mm nor more than 3 mm in diameter, mounted in the centre of the cup, and carrying two two-bladed brass propellers. The blades of both propellers shall be approximately 8 mm wide and shall be set at an angle of approximately 45°. The smaller (upper) propeller shall have an overall diameter of approximately 20 mm. The larger (lower) propeller shall have an overall diameter between 32 and 44 mm. The thickness of the propeller blades shall be neither less than 1.2 mm nor more than 2.0 mm. The collars on which the propeller blades are mounted shall have horizontal and vertical dimensions not greater than 10 mm. The plane of the centre of the upper propeller shall be 10 mm below the level of the rim of the cup. The plane of the centre of the lower propeller shall be 51 mm below the level of the rim of the cup. The level of the rim of the cup is in effect the level of the plane part of the portion of the under surface of the rim.

IS : 1209 - 1978

2) *Cover proper* — The cover proper (see Fig. 2) shall be of brass, and shall have a rim projecting downward almost to the flange of the cup and fitting the outside of the cup closely. The thickness of the cover measured just inside the rim, shall be not less than 0.8 mm and not more than 2 mm. There shall be a proper locating device, engaging with a corresponding locating device on the flange of the cup.

There shall be four openings in the cover (see Fig. 2) with the following dimensions:

- i) Opening *A* is an area defined by arcs of two concentric circles and the intersected lengths of two radii. The radius of the outer circle shall be not less than 22.4 mm and not more than 24.6 mm. The radius of the inner circle shall be not less than 13.5 mm and not more than 14.2 mm. The chord of the arc of the outer circle shall be not less than 12.7 mm and not more than 13.7 mm.
- ii) Openings *B* and *C* are of equal areas, each of the same general form as opening *A*, but of approximately half the (angular) width. The radii of the defining inner and outer circles shall be within the limits specified for the radii of the two circles, arcs of which partly define opening *A*. The chord of the outer arc for opening *B* or opening *C* shall be not less than 4.8 mm and not more than 5.6 mm. The sum of the areas of openings *B* and *C* shall be neither less than 75 percent, nor more than 100 percent of the area of opening *A*. Openings *B* and *C* shall be equally distant from opening *A* and radii drawn through each of their centres shall be at an angle of not less than 135° and not more than 140°.
- iii) Openings *A*, *B* and *C* need not conform exactly to the shape of geometrical figures bounded by arcs of two concentric circles and intersected lengths of radii. Their boundaries should, however, fall on or between the lines indicated by the limiting values of the dimensional specification of the preceding text and of Fig. 2.
- iv) Opening *D* is a split tube to grip the thermometer collar. Its centre is approximately 20 mm from the centre of the lid and on a radius at an angle of not less than 50° and not more than 60° to a radius passing through the centre of opening *C*. It shall be set at an angle of not less than 10°, and not more than 15° to the perpendicular. Its height shall be such that, when a standard thermometer is in position, the bottom of the bulb shall be 35.6 to 40.6 mm below the

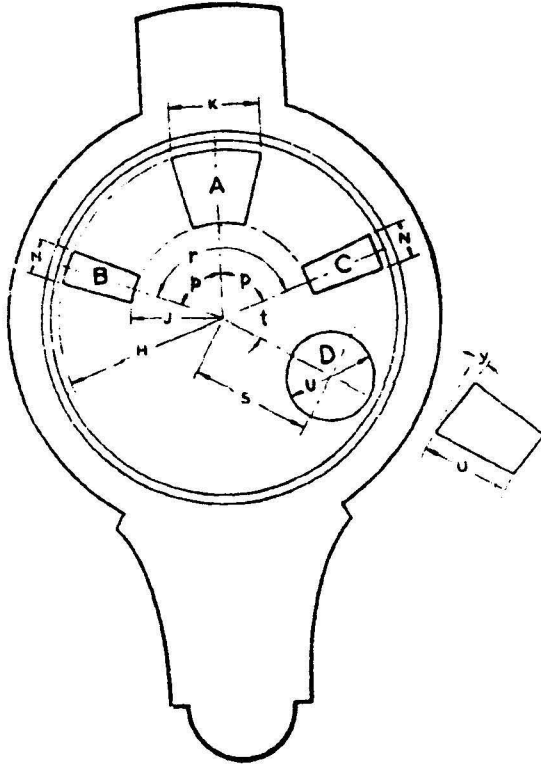

H — minimum 23.9 mm
maximum 24.6 mm

J — minimum 13.5 mm
maximum 14.2 mm

K — minimum 12.7 mm
maximum 13.7 mm

N — minimum 4.8 mm
maximum 5.6 mm

S — approximately 19.0 mm

U — approximately 12.7 mm

Angles *p* are equal

Angle *r* — minimum 135° maximum 140°

„ *t* „ 50° „ 60°

„ *y* „ 10° „ 15°

FIG. 2 COVER FOR PENSKY-MARTENS CLOSED TESTER

level of the rim of the cup (which corresponds to the lower surface of the portion of the lid inside the rim).

- 3) *Shutter* — The lid shall be equipped with a brass shutter, approximately 2.5 mm in thickness, operating on the plane of the upper surface of the lid. The shutter shall be so shaped and mounted that it rotates on the axis of the horizontal centre of the lid between the two stops, so placed that when in one extreme position, the openings *A*, *B* and *C* of the lid are completely closed and when in the other extreme position, these orifices are completely opened.
 - 4) *Flame-exposure device* — The flame-exposure device shall have a tip with an opening 0.7 to 0.8 mm in diameter. The flame-exposure device shall be equipped with an operating mechanism which, when the shutter is in the open position, depresses the tip so that the centre of the orifice is between the planes of the under and upper surfaces of the lid proper, at a point on a radius passing through the centre of the larger opening *A* and approximately 2.5 mm from the outer edge of the opening. A pilot flame for automatic relighting of the exposure flame should be provided. A bead, 4 mm in diameter of suitable material, may be mounted on the lid so that size of the test-flame can be regulated by comparison. The mechanism operating the shutter should be of the spring type and constructed so that when at rest the shutter shall exactly close the three openings *A*, *B* and *C*. When operated to the other extreme, the three openings in the lid shall be exactly open and the tip of the exposure tube shall be fully depressed. If the air bath is electrically heated and gas is not available, an oil burner shall be used to provide the test-flame, the position of which shall correspond with that of the gas flame previously specified.
- c) *Stove* — Heat shall be supplied to the cup by means of a properly aligned stove which is equivalent to an air bath. This stove shall consist of (1) an air bath, and (2) a top plate on which the flange of the cup rests.
- 1) *Air bath* — The air bath shall have a cylindrical interior, 41.3 to 42.2 mm in depth and a diameter not less than 3 mm and not more than 4 mm greater than the outside diameter of the cup. The air bath may be either a flame-heated metal casting or an electric-resistance element.

If the heating element is a flame-heated metal casting, it shall be so designed and used that the temperature of the bottom and walls is approximately the same. On this account it should be not less than 6 mm in thickness. The casting shall be

designed so that products of combustion of the flame cannot pass up and come in contact with the cup. If the air bath is of the electric-resistance type, it shall be constructed so that all parts of the interior surface are heated equally. This necessitates an even distribution of resistance wire to cover the bottom and walls, and a method of construction such that heat is given out from the whole core of the resistance element rather than directly from the wire.

The result obtained with the electrically heated instrument shall agree with that obtained with gas-heated apparatus within 1°C and 3°C respectively, according to whether the low or high range thermometer is used.

- 2) *Top plate* — The top plate shall be of metal. The total distance from the upper surface of the plate to the bottom of the air bath shall exceed the distance from the under surface of the flange to the bottom of the cup by not less than 1.6 mm and not more than 3 mm. The top plate shall be mounted with an air-gap between it and the air bath. The top plate may be attached to the air bath by means of three screws and spacing-bushings. The spacing-bushings should be of proper thickness to define the air-gap which shall be not less than 3 mm nor more than 4.8 mm. The spacing-bushings shall be not more than 9.5 mm in diameter.

- d) The thermometers conforming to the following requirements shall be used:

	<i>Low Range</i>	<i>High Range</i>
Range	- 7° to + 110°C	90 to 370°C
Graduation at each	0.5°C	2°C
Longer lines at each	1°C and 5°C	10°C and 20°C
Figures at each	5°C	20°C
Immersion	57 mm	57 mm
Overall length	280 ± 10 mm	280 ± 10 mm
Length of graduated portion	143 to 177 mm	143 to 177 mm
Bulb shape	Cylindrical	Cylindrical
Bulb diameter, <i>Max</i>	← Not larger than stem diameter →	diameter →
Stem diameter	5.5 to 8.0 mm	5.5 to 8.0 mm
Distance, bottom of bulb to lowest graduation	75 to 90 mm	75 to 90 mm
Expansion chamber	Required	Required
Top finish	Ring	Ring
Scale error, <i>Max</i> , plus or minus	0.5°C	1°C up to 260°C 2°C up to 260°C

IS : 1209 - 1978

Either of the thermometers may be employed if the indicated reading falls within 93 to 110°C. The thermometers shall be mounted securely in a thermometer collar so that the distance from the under side of the rim of the collar to the bottom of the bulb is 52 to 55 mm. The thermometer collar shall have an outside diameter of 12.70 ± 0.05 mm and a flange of 2.3 to 2.8 mm in thickness.

The cement used to fasten the thermometer into the collar shall be of such a nature that it will withstand the action of oil up to the highest temperature at which the thermometer is used. A swelling shall be provided to ensure the location of the thermometer collar at the correct point.

3.2 Procedure

3.2.1 Clean and dry all parts of the cup and its accessories thoroughly before the test is started. Take particular care to avoid the presence of any solvent used to clean the apparatus after a previous test. Fill the cup with the material to be tested up to the level indicated by the filling mark. Place the lid on the cup and set the latter in the stove. Take care that the locating devices are properly engaged. Insert the thermometer, high or low range, as required.

3.2.2 Light and adjust the test-flame so that it is of the size of a bead of 4 mm in diameter. Apply heat at such a rate that the temperature recorded by the thermometer increases between 5 to 6°C per minute.

Turn the stirrer at a rate of approximately 60 revolutions per minute. Apply the test-flame at each temperature reading which is a multiple of 1°C up to 104°C. For the temperature range above 104°C, apply the test-flame at each temperature reading which is a multiple of 2°C, the first application of the test-flame being made at a temperature at least 17°C below the actual flash point. Apply the test-flame by operating the device controlling the shutter and test-flame burner so that the flame is lowered in 0.5 seconds, left in its lowered position for one second, and quickly raised to its high position. Discontinue the stirring during the application of the test-flame.

3.3 Calculation

3.3.1 Observe and record the barometric pressure.

3.3.2 No corrections shall be made except in case of dispute, when the flash point figure shall be corrected according to the following rules:

- a) For each 25 mm below 760 mm barometric reading, add 1°C to the flash point;
- b) For each 25 mm above 760 mm barometric reading, subtract 1°C from the flash point.

3.4 Report — Unless otherwise specified, normally the flash point shall be taken as the temperature read on the thermometer at the time of the flame application that causes a distinct flash in the interior of the cup.

3.5 Precision — The duplicate test results should not differ by more than the following:

<i>Flash Point</i>	<i>Repeatability</i>	<i>Reproducibility</i>
104°C and below	2°C	3.5°C
Above 104°C	5.5°C	8.5°C

3.6 Precautions

3.6.1 The test-flame will neither be larger than stipulated nor will it be applied more frequently than specified as the surface layer is liable to be superheated.

3.6.2 The bluish halo that sometimes surrounds the test-flame shall not be confused with the true flash.

4. METHOD B (PENSKY-MARTENS — CLOSED), FOR DETERMINATION OF FLASH POINT FOR CUTBACK BITUMEN

4.1 Apparatus

4.1.1 Flash Point Tester — Pensky-Martens Closed Tester as described under 3.1.1 except that the stirrer shall be mechanically operated to stir in a downward direction at a speed of 70 to 80 rev/min.

4.1.2 Thermometer — Low range thermometer as specified in 3.1.1(d).

4.2 Procedure — Bring the material to be tested and the tester to a temperature of 17°C lower than the expected flash point. Completely fill the air space between the cup and the interior of the air bath with water at the temperature of the tester and material. Raise the temperature throughout the duration of the test at a rate of not less than 1°C and not more than 1.5°C per minute. Proceed as described in 3.2.2 except that :

- rate of heating to be not less than 1°C and not more than 1.5°C per minute,
- the rate of stirring to be 70-80 rev/min, and
- the test-flame to be applied at each 0.5°C rise in temperature.

4.3 Calculation and Report — Calculate and report the flash point as described under 3.3 and 3.4.

4.4 Precision — Duplicate tests shall not differ by the limits specified in 3.5.

5. METHOD C (PENSKY-MARTENS -OPEN), FOR DETERMINATION OF OPEN FLASH POINT AND FIRE POINT

5.1 Apparatus — The standard Pensky-Martens Tester and thermometers as prescribed in Method A (see 3.1.1) shall be used with the following modifications :

The cover of the cup shall be replaced by a clip which encircles the upper rim of the cup and carries the thermometer and test-flame. The tube carrying the thermometer shall have its centre on a radius at approximately 90° to the radius passing through the point of attachment of the test-flame, and shall be of such a height that when the thermometer is in position, its bulb shall be in the vertical axis of the cup and 12 mm below the filling line. The test-flame shall be fixed at the vertical axis of the cup and in level with the upper edge of the cup.

5.2 Procedure

5.2.1 All parts of the cup and its accessories shall be thoroughly cleaned and dried before the test is started. Particular care shall be taken to remove all traces of solvent used to clean the apparatus.

5.2.2 The cup shall be filled with the material to be tested up to the level indicated by the filling mark.

5.2.3 The clip carrying the thermometer and test-flame shall be placed on the cup and the latter set in the stove. Care shall be taken to have the locating devices properly engaged. The thermometer shall be inserted. If it is known that the material will flash above 104°C, higher range thermometer shall be used. Otherwise, it is preferable to start with the lower range thermometer and change if a temperature of 104 to 110°C is reached.

5.2.4 The test-flame shall be lighted and adjusted so that it is of the size of a bead 4 mm in diameter.

5.2.5 Heat shall be applied at such a rate that the temperature recorded by the thermometer increases neither less than 5°C nor more than 6°C per minute. The surface of the material shall be carefully observed during heating.

5.3 Report

5.3.1 Open Flash Point — The open flash point shall be taken as the temperature when a flash first appears at any point on the surface of the material.

5.3.2 Fire Point — The heating shall be continued until the oil ignites and continues to burn for 5 seconds. The temperature of the material, when this occurs shall be recorded as the fire point.

5.4 Precision — The following criteria should be followed for the acceptability of test results :

	<i>Repeatability</i>	<i>Reproducibility</i>
Flash point	8°C	11°C
Fire point	8°C	14°C

5.5 Precaution — Care shall be taken to shield the apparatus from draughts.

As in the Original Standard, this Page is Intentionally Left Blank

Indian Standard
**METHODS FOR TESTING
 TAR AND BITUMINOUS MATERIALS:
 FLOAT TEST**
(First Revision)

1. SCOPE

1.1 This standard covers the float test for bituminous materials.

2. APPARATUS

2.1 Float — Made of aluminium or aluminium alloy and conforming to Fig. 1 and the following requirements:

	<i>Min</i>	<i>Normal</i>	<i>Max</i>
Weight of float, g	37.70	37.90	38.10
Total height of float, mm	34.0	35.0	36.0
Height of rim above lower side of shoulder, mm	26.5	27.0	27.5
Thickness of shoulder, mm	1.3	1.4	1.5
Diameter of opening, mm	11.0	11.1	11.2

2.2 Collar — made of brass and conforming to Fig. 1 and the following requirements:

	<i>Min</i>	<i>Normal</i>	<i>Max</i>
Weight of collar, g	9.60	9.80	10.00
Overall height of collar, mm	22.3	22.5	22.7
Inside diameter of bottom, mm	12.72	12.82	12.92
Inside diameter at top, mm	9.65	9.70	9.75

2.2.1 The top of the collar shall screw up tightly against lower side of the shoulder.

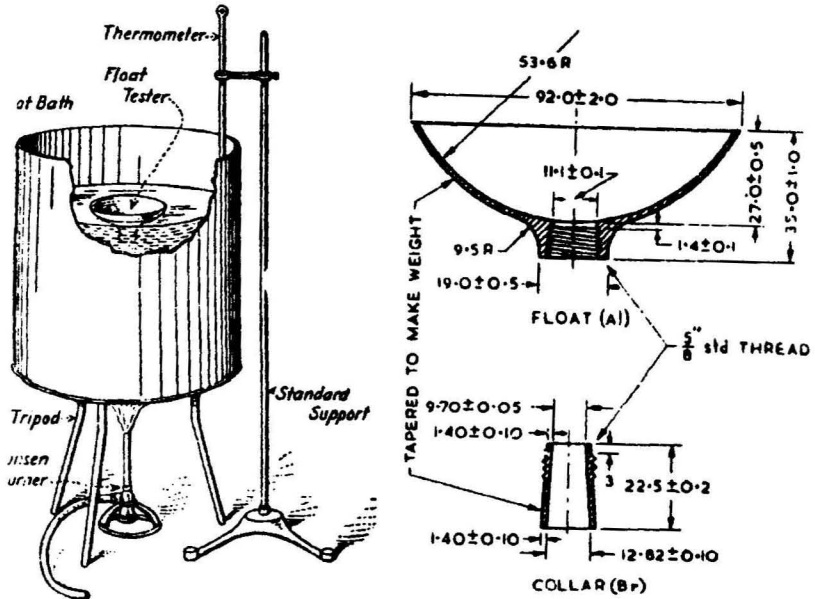

Weight of Float, 37.90 ± 0.20 g

Weight of Collar, 9.80 ± 0.20 g

Assembly of Apparatus

All dimensions in millimetres, except where otherwise stated.

FIG. 1 FLOAT TEST APPARATUS

2.3 Thermometer — Low softening point thermometer, graduated in centigrade scale and conforming to the following requirements:

Liquid	Mercury
Filling above liquid	Nitrogen gas
Temperature range	-2 to 80°C
Subdivisions	0.2°C
Longer graduation lines at each	1°C
Graduations numbered at each multiple of	2°C
Immersion, mm	Total

Total length	378 to 384 mm
Bulb length	9 to 14 mm
Bulb diameter	Not larger than stem diameter
Stem diameter	6.0 to 7.0 mm
Distance of bottom of bulb to graduation line at 0°C	75 to 90 mm
Distance of top of thermometer to graduation line at 80°C	30 to 45 mm
Expansion chamber to permit heating to at least	130°C
Top finish	Glass ring
Scale error at any point not to exceed	0.2°C

2.4 Bath — A water bath at least 185 mm in internal diameter and containing water at least 185 mm in depth. The height of the container above the surface of the water shall be at least 100 mm.

2.5 Calibration of Assembly — The assembly of the apparatus and dimensions additional to those given above are illustrated in Fig. 1. The assembled float and collar, with the collar filled flush with the bottom and weighed to a total weight of 53.2 g, shall float upon water with the rim 8.5 ± 1.5 mm above the surface of water.

3. PROCEDURE

3.1 Preparation of Sample — Place the brass collar with the smaller end on a brass plate which has been previously coated with equal parts of glycerine and dextrine. Melt completely a suitable quantity of residue from cutback bitumen (see 3.2.3.3 of IS : 1213-1978*) or the material itself for solid bitumen at the lowest possible temperature to bring it to a sufficiently fluid condition for pouring. Stir thoroughly until it is homogeneous and free from air bubbles and then pour it into the collar in any convenient manner until slightly more than level with the top.

3.1.1 Asphalt and Asphalt Products — Cool the material to room temperature for 15 minutes, place in water maintained at 5°C for 5 minutes, and trim the material flush with the top of the collar by means of a spatula or steel knife which has been slightly heated. Place the collar and plate in the water bath maintained at $5 \pm 1^\circ\text{C}$ and leave them in this bath for not less than 15 minutes and not more than 30 minutes.

*Methods for testing tar and bituminous materials : Distillation test (first revision).

IS : 1210 - 1978

3.1.2 Tar Products — Immediately immerse tar products for 5 minutes in the water bath at 5°C and trim the material flush with the top of the collar by means of a spatula or steel knife which has been slightly heated. Place the plate and collar in the water bath at 5°C and leave them in this bath for not less than 15 minutes and not more than 30 minutes.

3.2 Heat the bath water to the temperature at which the test is to be made. Maintain this temperature accurately without stirring and the temperature shall at no time throughout the test be allowed to vary by more than 0.5°C from the temperature specified. Determine the temperature by immersing the thermometer with the bottom of the bulb at a depth of 40 ± 2 mm below the water surface.

3.3 After the material to be tested has been kept in the ice water at 5°C for not less than 15 minutes, nor more than 30 minutes, remove the collar with its contents from the plate, screw into the aluminium float and immerse in water at 5°C for one minute. Remove the water, if any, from the inside of the float and immediately float the latter in the warm bath, making sure that the collar fits tightly into the float, and that there is no seepage of water between the collar and float during the test.

4. REPORT

4.1 Determine, by means of a stop watch, the time in seconds between placing the apparatus on the water and when the water breaks through the material. The mean of time taken in duplicate determination shall be reported.

5. PRECAUTIONS

5.1 Precautions shall be taken to ensure that the collar fits tightly into the float and to see that there is no seepage of water between the collar and float during the test.

Indian Standard
**METHODS FOR TESTING
TAR AND BITUMINOUS MATERIALS:
DETERMINATION OF WATER CONTENT
(DEAN AND STARK METHOD)**
(First Revision)

1. SCOPE

1.1 This standard covers the method for the determination of water content of asphalt bitumen and fluxed native asphalt, crude coal tar, road tar, cutback bitumen, Digboi type cutback bitumen and creosote and anthracene oil.

2. TERMINOLOGY

2.0 For the purpose of this standard, the following definition and those given in IS : 334-1965* shall apply.

2.1 Water Content — The quantity of water present in a material expressed as a percentage by mass of the material.

3. APPARATUS AND MATERIAL

3.1 Flask — of 500 ml capacity (*see* Fig. 1), made of heat resistant glass, well annealed and as free as possible from striae and similar defects. The top of the neck shall be ground to form the socket of a ground glass joint.

3.1.1 A metal flask may be used.

3.2 Condenser — made of heat resistant glass, well annealed and as free as possible from striae and similar defects, with shape, dimensions and tolerances shown in Fig. 2.

3.3 Receiver — made of heat resistant glass, well annealed and as free as possible from striae and similar defects, provided with ground glass joints with the dimensions and tolerances as given in Table 1 consisting essentially of the upper chamber, side tube with ground glass joint leading to the flask and the graduated tube. Numbered graduation marks shall be carried right round the receiver tube.

*Glossary of terms relating to bitumen and tar (*revised*).

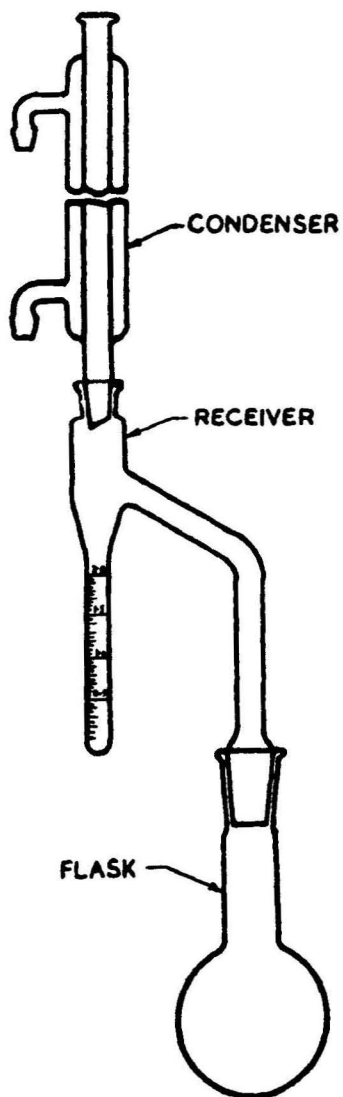
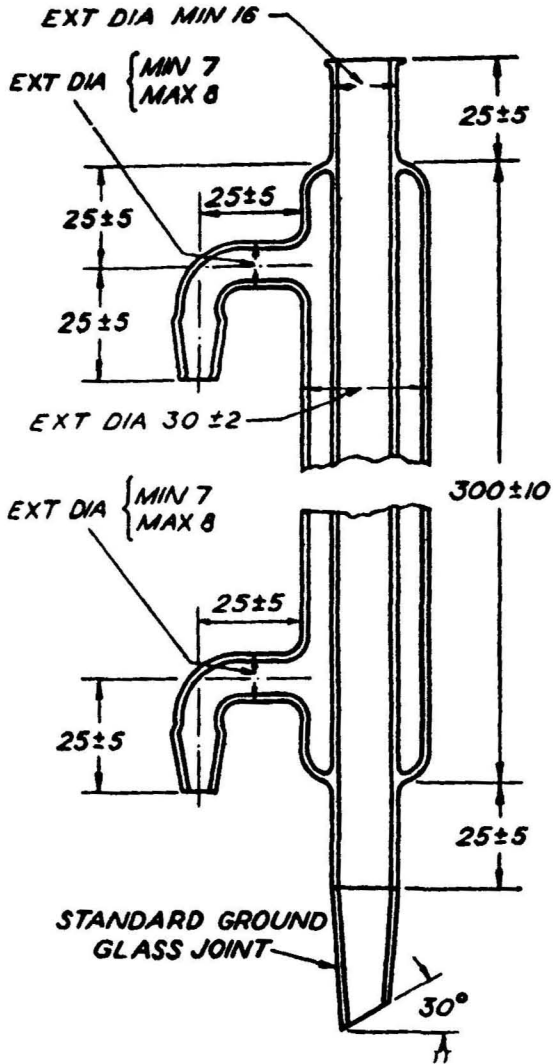

FIG. 1 DEAN AND STARK ASSEMBLY



All dimensions in millimetres.

FIG. 2 CONDENSER

IS : 1211 - 1978

The graduation marks midway between the numbered marks be carried about half way round the tube and the other marks shall be intermediate in length and shall project equally at each end beyond the shortest graduation marks.

TABLE 1 DETAILS OF RECEIVERS

(Clause 3.3)

CAPACITY OF RECEIVER IN ml AT 20°C	GRADUATION INTERVAL, ml	NUMBERING A EVERY GRADUATION	MAXIMUM ERROR ml	REF TO
2	0.1 to 2 in 0.05	0.5 ml	± 0.02	Fig. 3
10	1 to 10 in 0.1	1 ml	± 0.06	Fig. 4

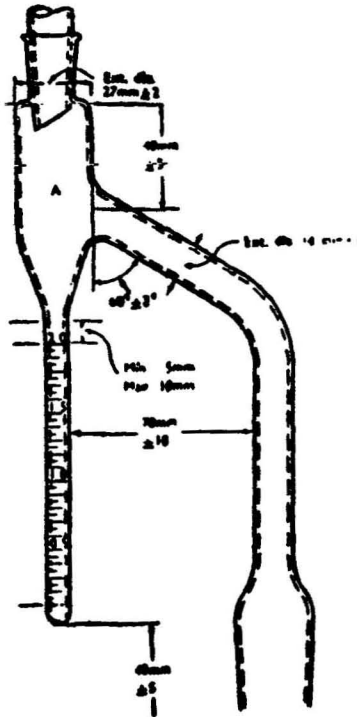

FIG. 3 2-ml RECEIVER (DEAN AND STARK APPARATUS)

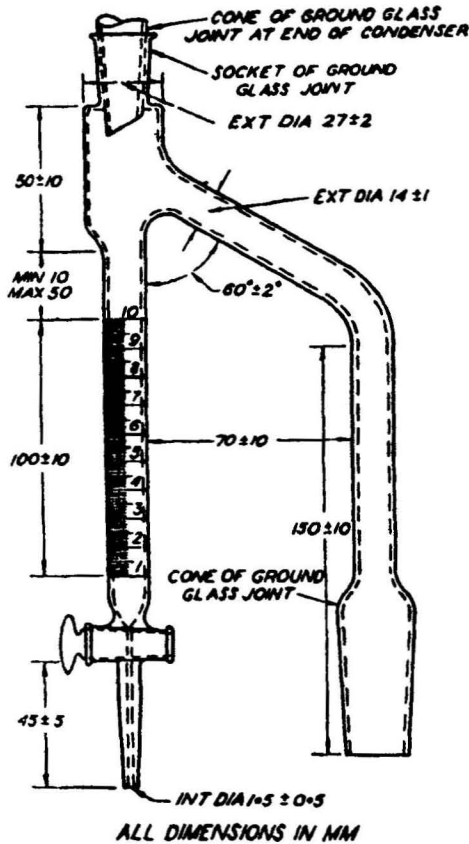

FIG. 4 10-ml RECEIVER (DEAN AND STARK APPARATUS)

3.3.1 When a metal flask is used, the receiver of the type shown in Fig. 3 and 4 without the ground glass joint shall be used and care shall be taken to provide an air-tight connection between the flask and the receiver.

3.4 A 100-ml Graduated Cylinder

3.5 Heater — Any suitable gas burner or electric heater may be used. A gas ring burner with ports on the inside circumference, shall be used with the metal still and shall be of such dimension that it may be moved up and down the vessel when testing materials that are likely to foam or solidify in the still.

IS : 1211 - 1978

3.6 Solvent — Carrier liquid shall be any one of the following:

3.6.1 Blend of 20 percent by volume of industrial grade toluene and 80 percent by volume of industrial grade xylene.

3.6.2 Petroleum or coal tar naphtha (IS : 213-1968*) free from water yielding not more than 5 percent distillate at 125°C and not less than 20 percent at 160°C.

3.6.3 Petroleum spirit with a boiling range of 100 to 120°C.

4. PROCEDURE

4.1 Place about 100 g of the sample, accurately weighed, in the flask and add 100 ml of solvent (*see* 3.6). Attach the flask to the Dean and Stark condensing and collecting system, and heat the flask at such a rate that the condensate falls from the end of the condenser at a rate of two to five drops per second. Continue the distillation until condensed water is no longer visible in any part of the apparatus except the bottom of the graduated tube and until the volume of water collected remains constant for a period not less than five minutes. Remove the persistent ring of condensed water in the condenser tube, if any, by increasing the rate of distillation by a few drops per second. Wash droplets of water which adhere to the lower end of the condenser tube into the receiver with solvent/carrier liquid using the spray tube. Insert a loose plug of cotton wool in the top of the condenser tube to prevent the condensation of atmospheric moisture in the condenser tube.

5. REPORT

5.1 Report the results as water content to the nearest 0.05 percent by weight if 2 ml receiver, has been used and to the nearest 0.1 percent if the 10 ml receiver has been used with 100 g of sample.

6. PRECISION

6.1 Duplicate determinations shall not differ by more than the following:

<i>Water Collected</i>	<i>Repeatability</i>	<i>Reproducibility</i>
0 to 1.0 ml	0.1 ml	0.2 ml
1.1 to 25 ml	0.1 ml or 2 percent of the mean whichever is greater	0.2 ml or 10 percent of the mean whichever is greater

*Specification for coal based naphtha (*first revision*).

Indian Standard
**METHODS FOR TESTING
TAR AND BITUMINOUS MATERIALS:
DETERMINATION OF LOSS ON HEATING**
(First Revision)

1. SCOPE

1.1 This standard covers the method for determination of loss on heating of asphaltic bitumens.

2. TERMINOLOGY

2.0 For the purpose of this standard, the following definition and those given in IS : 334-1965* shall apply.

2.1 Loss on Heating — The loss in weight (exclusive of water) of oil of a bituminous material when heated to a standard temperature and under specified conditions.

3. APPARATUS

3.1 Oven — A double-walled chamber, rectangular in form, interior dimensions not being less than 292 mm in height from the top of the heating element to the top of the chamber and not less than 298 mm in width and depth. The chamber is provided on one side with a tightly fitting hinged door containing a double-glass window, at least 100 mm square, through which the thermometer may be read without opening the door. Ventilation of the oven is provided by means of either one round vent-hole in the top and one in the bottom of the oven, or one round vent-hole near the top and one near the bottom on each of the two sides of the oven, the diameter of each vent-hole being 12 to 16 mm. Heating of the oven is done by means of electricity and the temperature is maintained within the limits specified for the test.

3.2 Perforated Metal Shelf — A perforated metal shelf approximately 250 mm in diameter; an aluminium shelf of the form and dimensions shown in Fig. 1, is recommended. The shelf is placed in the centre of the oven with respect to all dimensions of the interior

*Glossary of terms relating to bitumen and tar (*revised*).

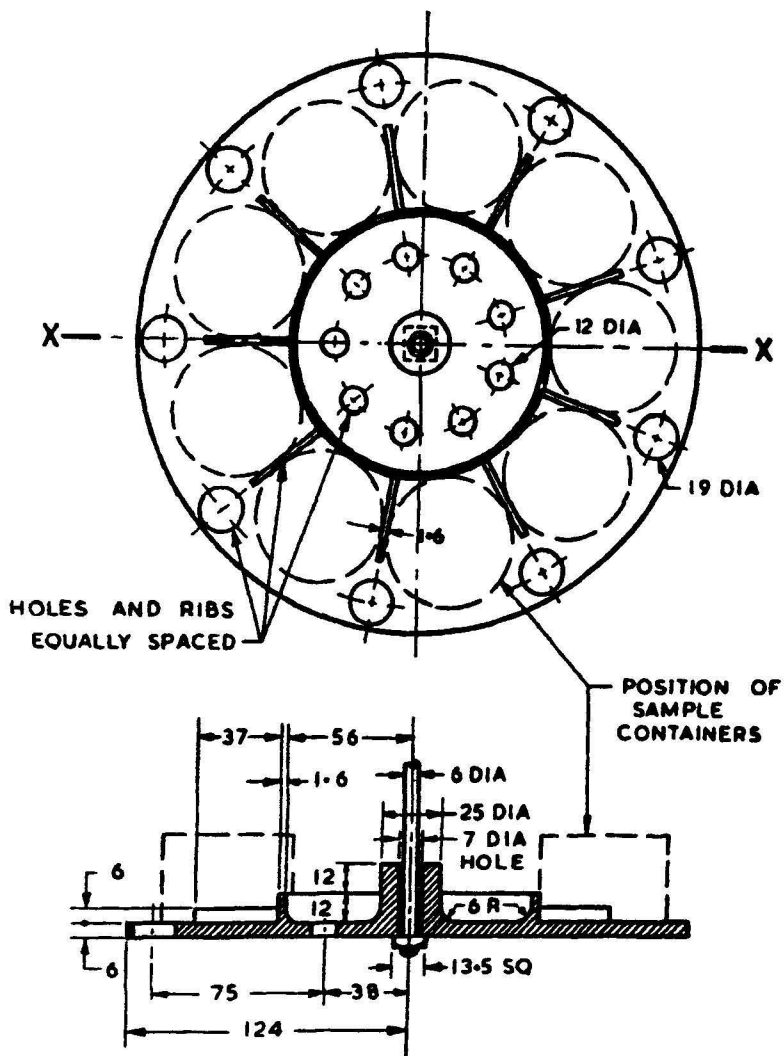

SECTION XX

All dimensions in millimetres.

FIG. 1 ALUMINIUM SHELF FOR LOSS ON HEATING TEST

of the oven, and is suspended by a vertical shaft and provided with mechanical means for rotation at the rate of 5 to 6 rev/min.

3.3 Thermometer — A thermometer graduated in centigrade degrees, and conforming to the following requirements shall be used:

Liquid	Mercury
Filling above liquid	Nitrogen gas
Temperature range	155 to 170°C
Subdivisions	0.5°C
Longer graduation lines at each	1°C
Graduations numbered at	0°C, 155°C, 163°C and 170°C
Immersion	Total
Total length	150 to 154 mm
Bulb length	10 to 15 mm
Bulb diameter	Not larger than stem diameter
Stem diameter	6.0 to 7.0 mm
Distance of bottom of bulb to graduation line :	
At 0°C	33 to 38 mm
At 155°C	70 to 80 mm
Distance of top of thermometer to graduation line at 170°C	20 to 30 mm
Top finish	Glass ring
Scale error at any point when standardized, <i>Max</i>	0.5°C

3.3.1 The top of the contraction chamber shall be not more than 41 mm above the bottom of the bulb.

3.3.2 The expansion chamber shall permit heating the thermometer at least 25°C above the highest temperature on the scale.

3.3.3 At the ice point, the thermometer shall be graduated from -1°C to +1°C in 0.5°C divisions.

3.3.4 The thermometer shall be supported from the shaft of the metal shelf in a vertical position, approximately 20 mm inside the periphery of the shelf with the bottom of the bulb 6 mm above the shelf.

3.4 Container — of metal or glass, cylindrical in shape with a flat bottom and with internal diameter 55 mm and internal depth 35 mm.

IS : 1212 - 1978

4. PROCEDURE

4.1 Stir and agitate thoroughly the material as received, warming, if necessary, to ensure a complete mixture before a portion is removed for the test.

4.2 Heat the container in an oven at 100 to 110°C for 30 minutes, cool and weigh. Weigh into the container 50.0 ± 0.5 g of the material correct to the nearest 0.01 g.

4.3 Bring the oven to a temperature of $163 \pm 1^\circ\text{C}$ and place the sample container in the revolving shelf near the circumference or in one of the recesses if the recommended shelf is used. Close the oven and rotate the shelf during the entire test at a rate of 5 to 6 rev/min, the temperature being maintained at $163 \pm 1^\circ\text{C}$ for 5 h after the sample has been introduced and the oven has again reached the temperature.

The 5 hour period shall start when the temperature reaches 162°C and in no case shall the total time, during which the sample is in the oven, be more than 5 hours 15 minutes. At the end of the specified heating period, remove the containers, cool to room temperature and weigh to 0.01 g.

4.3.1 In ordinary circumstances, a number of samples having about the same degree of volatility may be tested at the same time, but samples varying greatly in volatility shall be tested separately. However, when extreme accuracy is required, only one material, that is, two containers shall be placed in the oven at one time.

4.4 When the penetration of the sample after heating is to be determined, melt the residue in the container at the lowest possible temperature and thoroughly mix it by stirring, taking care to avoid incorporating air bubbles in the material. Pour the residue into the container specified under 3.1 of IS : 1203-1978* and from the pouring stags follow the procedure as described under 4.1 of IS : 1203-1978*.

5. REPORTING

5.1 Report to the nearest 0.05 percent the mean percentage loss in weight for the duplicate determinations, correcting for water content, if any. Report also the water content.

*Methods for testing tar and bituminous materials : Determination of penetration (first revision).

6. PRECISION

6.1 Results of duplicate tests shall not differ by more than the following:

<i>Loss on Heating percent</i>	<i>Repeatability</i>	<i>Reproducibility</i>
0 to 0.5	0.1	0.2
0.5 to 1.0	0.2	0.4
1.0 to 2.0	0.3	0.6
Above 2.0	10 percent of mean	20 percent of mean

NOTE — In this case the repeatability figures refer to the differences between duplicate determinations made simultaneously in the same oven.

7. PRECAUTIONS

7.1 Conduct the loss on heating test in duplicate.

7.2 Determine the water content of the sample in accordance with the method for determination of water content specified in IS : 1211-1978*.

7.3 If the sample contains water, test it in that condition.

7.4 Reject the tests during which samples show evidence of loss by foaming.

*Methods for testing tar and bituminous materials : Determination of water content (Dean and Stark method) (*first revision*).

As in the Original Standard, this Page is Intentionally Left Blank

Indian Standard
**METHODS FOR TESTING
 TAR AND BITUMINOUS MATERIALS:
 DISTILLATION TEST**
(First Revision)

1. SCOPE

1.1 This standard covers the methods for the distillation test for crude coal tar, road tar, cutback bitumen, Digboi type cutback bitumen and creosote and anthracene oil.

2. TERMINOLOGY

2.0 For the purpose of this standard, the following definition and those given in IS : 334-1965* shall apply.

2.1 Distillation — The process by which the more volatile constituents are separated from the less volatile ones.

3. METHOD A (FOR CUTBACK BITUMEN)**3.1 Apparatus**

3.1.1 Distillation Flask — 500 ml, side arm having dimensions as shown in Fig. 1.

3.1.1.1 The distance from the centre of the side tube at the junction of the neck to the top of the neck shall be 12 ± 1 mm.

3.1.1.2 The side tube shall slope downwards from the junction with neck so that the acute angle between the side tube and the neck is $75 \pm 3^\circ$.

3.1.2 Thermometer — of high distillation, total immersion type, graduated in centigrade degrees as specified, having a range of -2 to 400°C and conforming to the following requirements:

Liquid	Mercury
Filling above liquid	Nitrogen gas
Temperature range	-2 to 400°C

*Glossary of terms relating to bitumen and tar (*revised*).

IS : 1213 - 1978

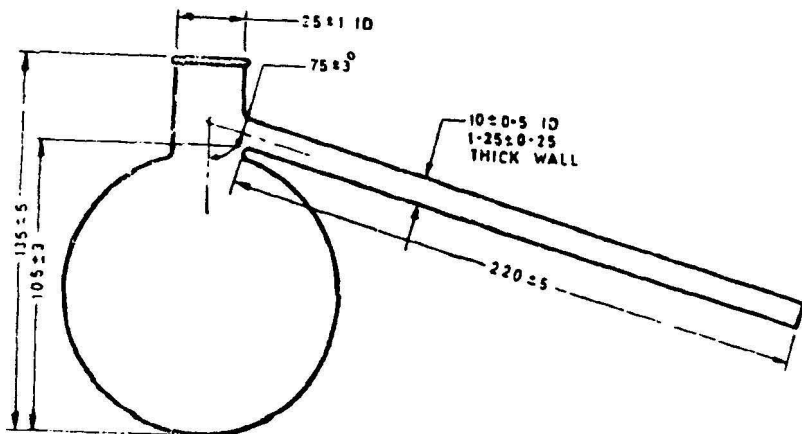

All dimensions in millimetres.

FIG. 1 DISTILLATION FLASK

Subdivision	1°C
Total length	378 to 384 mm
Stem diameter	6.0 to 7.0 mm
Bulb diameter	Not larger than stem diameter
Bulb length	10 to 15 mm
Distance of bottom of bulb to graduation line at 0°C	25 to 45 mm
Top finish	Glass ring
Longer graduation lines at each	5°C
Graduations numbered at each multiple	10°C
Immersion	Total
Scale error at any point up to 370°C shall not exceed	1°C

3.1.3 Condenser (Water) — A 250-mm glass-jacketed condenser (see Fig. 2) with the dimensions and tolerances given below:

Length of jacket excluding the necks	250 ± 5 mm
Outside diameter of adapter of condenser tube	23 ± 1 mm
Length of adapter	75 ± 5 mm

Outside diameter of condenser tube proper	12.5 ± 0.5 mm
Overall length of condenser tube including adapter	475 ± 25 mm

3.1.4 Adapter — of curved design (see Fig. 2) having a heavy wall (one millimetre) and reinforced top glass, with an angle of approximately 105° and with a diameter at the large end of approximately 18 mm. The outlet end shall be ground to an angle of $45 \pm 5^\circ$ with inside vertical. The small end shall have a diameter of not less than 5 mm.

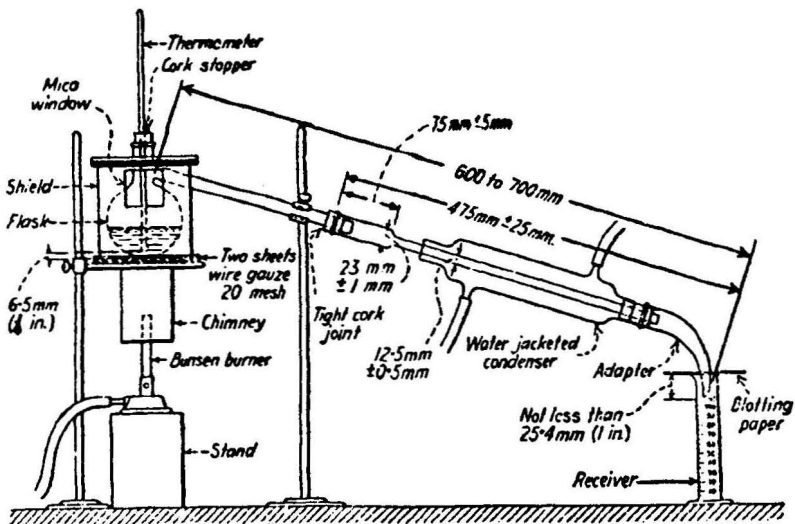
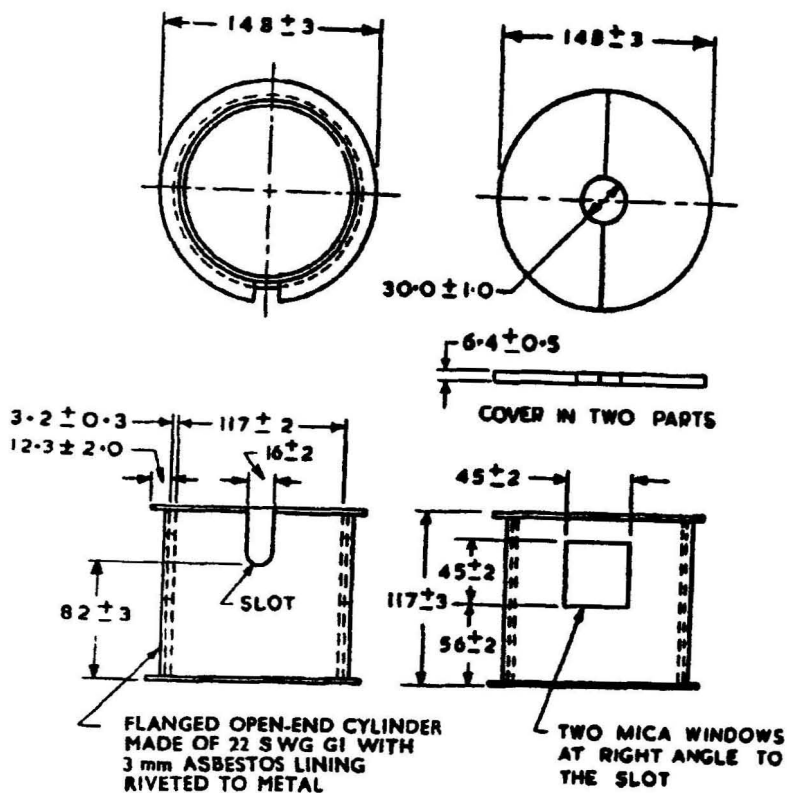

FIG. 2 DISTILLATION APPARATUS ASSEMBLY

3.1.5 Shield — of galvanized iron, lined with 3-mm asbestos, fitted with transparent covered windows, of the form and dimensions shown in Fig. 3; used to protect the flask from air currents and to prevent radiation. The cover (top) may be of transit board made in two parts, or it may be of galvanized iron lined with 3-mm asbestos.

3.1.6 Crow Receivers — of 25 ml, 50 ml or 100 ml size and of dimensions and tolerances shown in Fig. 4 may be used.

3.1.7 Residue Container — The container for the distillation residue shall be a 250 g metal container approximately 76 mm in diameter and 54 mm deep, provided with a lid.



All dimensions in millimetres.

FIG. 3 SHIELD

3.2 Procedure

3.2.1 Preparation of the Sample — Distil a known volume of the thoroughly mixed sample from the distillation flask with the condenser, until water ceases to come over. Separate the water from the oil and return the oil to the distillation residue when the residue has cooled to 40°C. This procedure shall be adopted only if the water content of the material, as determined according to IS : 1211-1978* is in excess of 0.5 percent.

*Methods for testing tar and bituminous materials : Determination of water content (Dean and Stark method) (first revision).

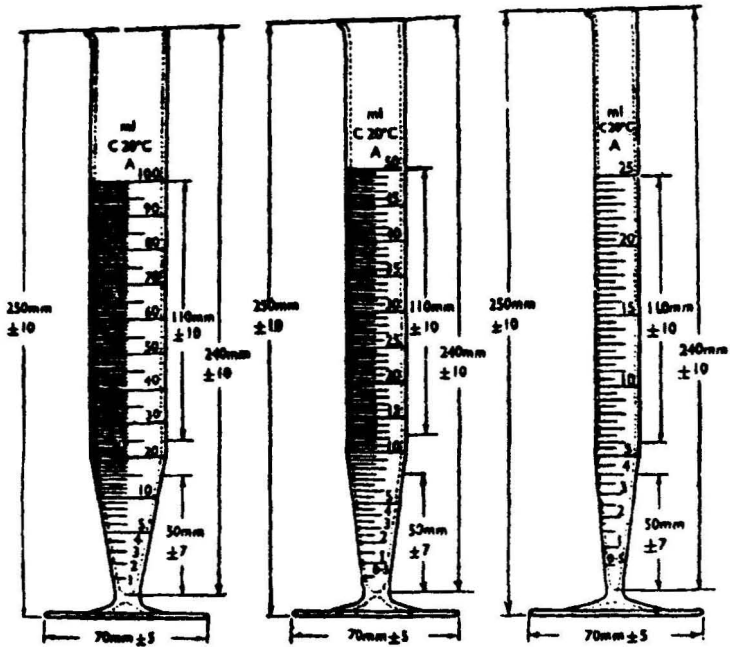

FIG. 4 CROW RECEIVERS 100 ml, 50 ml AND 25 ml

3.2.1.1 Thoroughly stir and agitate the sample if necessary to ensure a complete mixture.

3.2.2 Assembly of Apparatus

3.2.2.1 Support the flask on a tripod or ring over two sheets of IS 20 mesh wire gauze, 150 mm square (see Fig. 2). Connect to the condenser tube by a light cork joint. Insert the thermometer through a cork in the neck of the flask with the bottom of the bulb 6 mm from the bottom of the flask, the axis of the bulb of the flask through the centre of the neck being vertical and the thermometer aligned on this axis.

3.2.2.2 The distance from the neck of the flask to the outlet end of the adapter shall be not more than 700 mm and not less than 600 mm. The burner should be protected from draughts by a suitable shield or chimney (see Fig. 3).

3.2.2.3 Adjust the adapter over the end of the condenser tube so as to conduct the distillate into the receiver. During the distillation, cover closely the top of the receiver with a piece of blotting paper or its

IS : 1213 - 1978

equivalent, which shall be cut so as to fit the adapter tightly. The adapter shall extend into the receiver at least 25 mm but not below the 100-ml mark.

3.2.3 *Distillation*

3.2.3.1 Measure 200 ml of the material into the flask, assemble the apparatus and heat so that the first drop comes over in 5 to 15 minutes. Adjust the rate of distillation between 50 to 70 drops per minute except that near the end of the distillation the heat input shall not be so rapid as to result in a temperature in excess of 360°C.

3.2.3.2 Should the sample foam, the distillation rate will have to be reduced, but the normal rate shall be resumed as soon as possible. If excess foaming persists, the distillation may be more easily controlled by applying the flame near the edge of the bulb and not at the centre.

3.2.3.3 Collect the distillate in the crow receivers and record the volume of distillate at all specified temperatures. Record also the volume of any separate water. When the maximum specified temperature of the test is indicated by the thermometer, discontinue the heating and drain into the receiver any oil which may remain in the condenser tube. Measure by volume the residue and keep it for further tests.

3.2.4 *Procedure for Handling Residue*

3.2.4.1 When the temperature reaches 360°C, extinguish the flame and immediately (within 30 seconds) pour the residue into the residue container, placing this on its lid to prevent too rapid cooling at the bottom.

3.2.4.2 Allow the residue to cool in a position free from draughts to a temperature that is below its fuming point and at the same time suitable for pouring.

3.2.4.3 Stir the residue and pour into the receptacles specified for testing for properties, such as penetration and softening point.

3.3 Report

3.3.1 *Asphaltic Residue* — Calculate the percent residue to the nearest 0.1 as follows :

$$R = [(200 - TD)/200] \times 100$$

where

R = residue content, in volume percent; and
 TD = total distillate recovered to 360°C, in ml.

3.3.1.1 Report as the residue from distillation to 360°C, percent volume by difference.

3.3.2 Total Distillate — Calculate the percent total distillate to the nearest 0.1 as follows:

$$TD \text{ percent} = (TD/200) \times 200$$

3.3.2.1 Report as the total distillate to 360°C, volume percent.

3.3.3 Distillate Fractions

3.3.3.1 Determine the percentage by volume of the original sample by dividing the observed volume (in millilitres) of the fraction by 2. Report to the nearest 0.1 as volume percent as follows:

Up to 190°C

Up to 225°C

Up to 260°C

Up to 316°C

3.3.3.2 Determine the percentages by volume of total distillate by dividing the observed volume in millilitres of the fraction by the millilitres recovered to 360°C and multiply by 100. Report to the nearest 0.1 as the distillate, volume percent of total distillate to 360°C as follows:

Up to 190°C

Up to 225°C

Up to 260°C

Up to 316°C

3.3.4 Where penetration, viscosity, or other tests have been carried out, report with reference to this method as well as to any other method used. (Example 'Penetration according IS : 1203-1978* of residue as in IS : 1213-1978').

3.3.5 If the first fraction obtained contains water, note the volume of water. Deduct this from the volume of oil taken and correct all the fractions to a percentage based on the volume of the water-free sample.

3.3.6 A convenient method for determining the volume of water is to transfer this fraction, after noting the volume, to a tube or cylinder graduated in 0.1 ml and to add about 15 to 20 ml of benzol. This almost always causes a clear separation between the oil and water.

3.3.7 Barometric pressure correction as stipulated under 8 shall be applied where necessary.

3.4 Precision — Duplicate results shall not differ by more than the following:

Repeatability

2 ml distillate

Reproducibility

4 ml distillate

*Methods for testing tar and bituminous materials: Determination of penetration (first revision).

3.5 Precautions — During the progress of distillation, the thermometer shall remain in its original position. No correction shall be made for the emergent stem of the thermometer.

4. METHOD B (FOR ROAD TAR)

4.1 Apparatus

4.1.1 Distillation Flask — A flask with dimensions and tolerances as given below shall be used:

Distillation capacity, ml	750
Capacity of bulb, ml	975 ± 20
Internal diameter of neck between side taper and bulb, mm	28 ± 1
Internal diameter of side tube, mm	8.5 ± 0.5
External diameter of side tube, mm	11.0 ± 0.5
Length of side tube, mm	160 ± 5
Radius of curvature at the base of the neck, mm	12
Thickness of walls of bulb neck of side tube, mm	1.0 to 1.5

4.1.1.1 The distance from the centre of the side tube of each flask at the junction of the neck to the top of the neck shall be 75 ± 3 mm. The distance from the centre of the side tube of each flask at the junction with the neck to the liquid surface, when the flask is vertical and contains a quantity of liquid equal in volume to the distillation capacity of the flask, shall be 90 ± 3 mm.

4.1.2 Thermometer — same as for Method A (see 3.1.2).

4.1.3 Air Condenser — made from a straight tube of good quality resistance glass, with one end finished square with the axis and the other end ground at an angle of 45° with the axis and conforming to the following dimensions:

Internal diameter	20 ± 1 mm
Overall length	600 ± 10 mm
Wall thickness	1.0 to 1.5 mm

4.1.3.1 The side arm of the flask shall extend at least 25 mm beyond the cork in the upper end of the condenser.

4.1.4 Draught Screen — rectangular, made of 0.711 mm Standard Wire Gauge sheet metal, with the dimensions shown in Fig. 5 and open at top and bottom and complying with the following requirements:

In each of the two narrow sides of the draught screen there shall be two circular holes, 25 mm in diameter each, and situated as illustrated in Fig. 5. In each of the four sides of the draught screen there shall be three holes with their centres 25 mm above the base of the draught screen. These holes shall occupy the positions as shown in Fig. 5. The diameter of each of the holes centrally situated in the longer sides shall be 25 mm and of the remaining ten holes 12 mm. At the middle of each of the wider sides a vertical slot with the dimensions as shown in Fig. 5 shall be cut downwards from the top of the screen.

A sheet of hard asbestos of silica board, 6 mm in thickness and having a central circular hole 110 mm in diameter, shall be supported horizontally in the screen and shall fit closely to the sides of the screen to ensure that hot gases from the source of heat do not come in contact with the sides of neck of the flask. The flask shall be placed in position and pressed down so as to close completely the hole in the board. The supports for this board may conveniently consist of triangular pieces of metal sheet firmly fixed to the screen at its four corners.

In one of the narrow side of the screen a door shall be provided, having the dimensions and position as shown in Fig. 5. In each of the narrow sides of the screen a mica window shall be placed centrally, with bottom of the window level with the top of the asbestos shelf. The dimensions and position of the windows shall be as shown in Fig. 5.

4.1.5 Crow Receivers — same as specified in Method A (see 3.1.6).

4.2 Procedure

4.2.1 Preparation of the Sample — same as specified in Method A (see 3.2.1).

4.2.2 Assembly of Apparatus — Set up the distillation flask complete with thermometer, air condenser and receiver. The thermometer shall be so fitted in the flask that the bottom of the capillary is level with the lower edge of the side tube joint and the immersion mark is level with the top of the cork.

4.2.3 Distillation

4.2.3.1 Weigh 750.0 ± 0.5 g of the material into the weighed distillation flask, and assemble the apparatus, using the 25-ml receiver to collect the first fraction. Place this and the subsequent

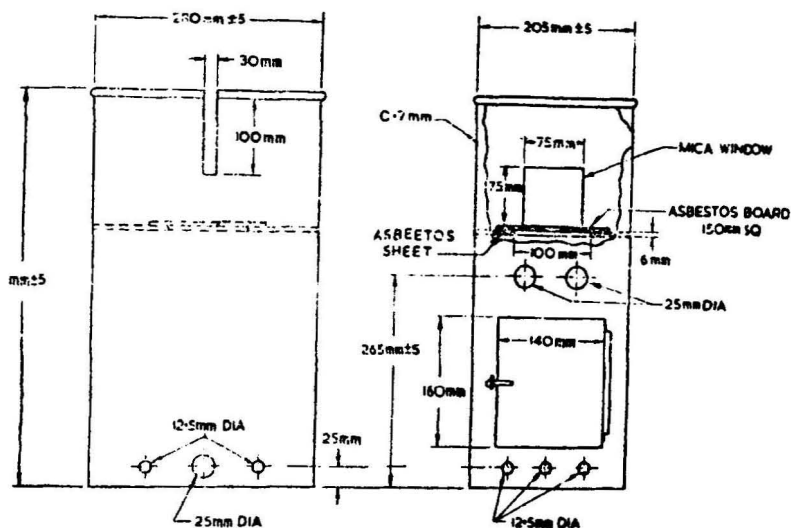

FIG. 5 DRAUGHT SCREEN

receivers so that the condensate will flow down the sides. Apply heat at such a rate that the thermometer indicates 200°C within 35 ± 5 min from the start.

4.2.3.2 When examining tars which are liable to froth on heating, it may be found that the temperature cannot be brought satisfactorily to 200°C within the maximum specified period of 35 ± 5 minutes. Only in the testing of such tars which froth excessively may the preliminary period of heating be extended and then only just sufficiently for the purpose. In such an event, record the time taken to reach 200°C .

4.2.3.3 As soon as oil commences to distil, adjust the flame so that 5 ml of distillate collect in not less than 54 but not more than 66 seconds. Maintain this distillation rate, which corresponds to 5.0 ± 0.5 ml/min throughout the remainder of the distillation except that the collection of the first 5 ml in any receiver may extend over 75 s as the upper limit, and if the collection of any 5 ml extends over less than 54 or more than 66 s, the collection of 15 ml, including that 5 ml portion, shall extend over at least 165 but not more than 195 seconds.

4.2.3.4 If in any test, the conditions specified in 4.2.3.3 are not met, the test shall be discarded and another test carried out with a further portion of the material.

4.2.3.5 The specified distillation rate corresponds approximately to 90 drops/min or 3 drops in each 2 s, but this should be taken only as a guide. Graduated receivers should be used for the collection of the distillate so that the time taken to collect each 5 ml may be kept under close observation.

4.2.3.6 Make a record of these times throughout the test so that compliance with the distillation requirements may be subsequently checked.

4.2.3.7 When the thermometer indicates 200°C, replace the 25-ml receiver by another receiver which has been warmed immediately before use, so that naphthalene is prevented from solidifying on its inner wall and thus interfering with the checking of the distillation rate.

4.2.3.8 Take the other fractions at 270°C and 300°C or at such other temperatures as may be specified, in the 100-ml receivers, the receivers being changed without interrupting the distillation.

4.2.3.9 Extinguish the Bunsen flame immediately the highest specified temperature is reached. Include, in the final fraction, oil which drains from the condenser within five minutes after the flame is extinguished.

4.2.3.10 Should solids tend to deposit during distillation, warm the condenser so that such solids are collected in the fraction with which they come over.

4.2.3.11 Ascertain the weight of the distillate to 200°C in g, note the volume of the water and, assuming a density of 1.00 g/ml, record the weight of water in grams. Find the weight of the light oil in the fraction up to 200°C by difference. Determine the weights of other fractions in the same manner.

4.2.3.12 In addition, note the volumes of the fractions 'up to 200°C' and '200 to 270°C' and reserve for use in connection with the determination of phenols (*see IS : 1218-1978**).

4.2.3.13 Keep the flask with the cork and the thermometer in position for one hour after the flame has been extinguished. Then weigh the flask and residue, after which mix the contents of the flask thoroughly by shaking. Pour out half. Again shake the remainder and determine softening point by the method illustrated in IS : 1205-1978†.

4.3 Report — Carry out the distillation test and report the separate results and the average as percentage by weight on the sample. Report the time in seconds for each 5 ml of distillate.

*Methods for testing tar and bituminous materials : Determination of phenols (*first revision*).

†Methods for testing tar and bituminous materials : Determination of softening point (*first revision*).

IS : 1213 - 1978

4.3.1 Barometric pressure correction as stipulated under 8 shall be applied where necessary.

4.4 **Precision** — The mean of two results conducted by the same laboratory should not differ from the mean of the two results in 2nd laboratory by more than the following:

- | | |
|---|------------------------|
| a) 200-270°C | 1.0 percent <i>m/m</i> |
| b) 270-300°C | 1.0 percent <i>m/m</i> |
| c) Sum of (a) and (b) | 1.5 percent <i>m/m</i> |
| d) Softening point of the residue (R & B) | 3°C |

5. METHOD C (FOR CRUDE COAL TAR)

5.1 Apparatus

5.1.1 *Distillation Flask* — same as specified in Method B (see 4.1.1).

5.1.2 *Thermometer* — same as specified in Method A (see 3.1.2).

5.1.3 *Air Condenser* — same as specified in Method B (see 4.1.3).

5.1.4 *Metal Heating Bath* (See Fig. 6) — The bath shall contain fusible alloy melting below 70°C in such quantity that when the bottom of the flask is 5 mm from the bottom of the bath, the level of the molten metal is about 15 mm below the rim of the bath.

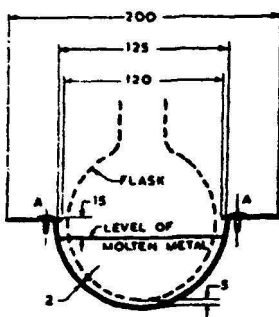

A, A : Three or Four Pins or Similar Device to Retain Flange Central, if Flange and Bowl are not in One Piece.

All dimensions in millimetres.
Dimensions in minima.

FIG. 6 METAL HEATING BATH

5.1.5 *Crow Receivers* — same as specified in Method A (see 3.1.6).

5.2 Procedure

5.2.1 Preparation of Sample — same as specified in Method A (see 3.2.1).

5.2.2 Assembly of Apparatus — Set up the distillation flask as in Method B (see 4.2.2).

5.2.2.1 Smoke the bottom of the flask over a luminous flame. Heat the fusible metal to a temperature slightly higher than its melting point and immerse the flask centrally in the bath, the bottom of the flask being at least 5 mm above the bottom of the bath.

5.2.3 Distillation — Take 250 ml of the material and carry out the distillation steadily at the rate of 5 ml/min and, without interrupting the distillation, collect oil fractions separately in the graduated receiver as follows:

- a) Up to 210°C
- b) 210 to 230°C
- c) 230 to 270°C
- d) 270 to 300°C
- e) 300°C to the stage of pitch

5.2.3.1 Should solids tend to deposit during the distillation, warm the condenser so that such solids are collected in the fraction with which they come over.

5.3 Report

5.3.1 Record the final temperature of distillation reached in the test.

5.3.2 Note and report the volume and appearance of each fraction. Determine and report the specific gravity of each fraction at 27°C. Nucleate fractions (a) to (d) with a small crystal of naphthalene and fraction (e) with a small crystal of anthracene and cool the fractions to $15.5 \pm 0.5^\circ\text{C}$. Keep at this temperature, with occasional stirring, till solids separate out or for 4 hours, whichever is less, and report the result of this observation and the percentage of oil draining out of each fraction in which solids make an appearance.

5.3.3 Barometric pressure correction as stipulated under 7 shall be applied where necessary.

6. METHOD D (FOR CREOSOTE AND ANTHRACENE OIL)

6.1 Apparatus

6.1.1 Distillation Flask — A flask with dimensions and tolerances as given below shall be used:

Distillation capacity	150 ml
Capacity of bulb	195 ± 7 ml

Internal diameter of neck between side, taper and bulb	18 ± 1 mm
Internal diameter of side tube	5.0 ± 0.5 mm
External diameter of side tube	7.0 ± 0.5 mm
Length of side tube	120 ± 4 mm
Radius of curvature at the base of neck	10 mm
Thickness of walls of bulb, neck, side tube	0.8 to 1.2 mm

6.1.2 *Thermometer* — same as specified in Method A (see 3.1.2).

6.1.3 *Air Condenser* — same as specified in Method B (see 4.1.3).

6.1.4 *Draught Screen* — same as specified in Method B (see 4.1.4).

6.1.5 *Receivers* — same as specified in Method A (see 3.1.6).

6.2 Procedure

6.2.1 *Preparation of Sample* — same as specified in Method A (see 3.2.1).

6.2.2 *Assembly of Apparatus* — same as specified in Method B (see 4.2.2).

6.2.3 Distillation

6.2.3.1 Thoroughly mix the sample as prepared under 6.2.1 in a 250-ml flask. Weigh 100 ± 0.5 g of the mixture directly into the weighed distillation flask and start the distillation, using the naked flame of the burner. Continue the distillation at the rate of 5.0 ± 0.5 ml per minute. If for any reason the distillation rate falls outside the specified limits at any time after the first 5 ml of distillate have collected and before the final specified temperature is reached, discard the test and start another test on a further portion of the material.

6.2.3.2 The specified distillation rate corresponds approximately to 90 drops per minute or three drops in each two seconds, but this should only be taken as a guide. Graduated receivers should preferably be used for the collection of the distillate in order that the rate in millilitres per minute may be kept under close observation.

6.2.3.3 Change the receiver at each specified temperature (see 6.3) without stopping the distillation. Extinguish the flame when the thermometer reaches the highest specified temperature, and include in the final fraction the oil which drains from the condenser within five minutes after the flame has been extinguished. Should solids tend to deposit during the distillation, warm the condenser so that such solids are collected in the fraction with which they come over.

6.2.3.4 During the progress of distillation, the thermometer shall remain in its original position. No correction shall be made for the emergent stem of the thermometer.

6.3 Report

6.3.1 Report the cumulative weights of fractions obtained at the following ranges of temperatures:

0 to 210°C

0 to 235°C

0 to 315°C

0 to 355°C

6.3.2 Also, report the weight of the residue

6.3.3 If the first fraction contains water, determine the amount of water. Deduct this amount from the weight of oil taken for the test, and report all the fractions as percentage by weight based on the weight of the water-free material.

6.3.4 A convenient method for determining the amount of water is to transfer this fraction, after weighing, to a tube of cylinder graduated in 0.1 ml and to add 13 to 20 ml of benzol. This almost always causes a clear separation between the oil and water, and assuming a density of 1.00 g/ml, the weight of water can be calculated.

6.3.5 Barometric pressure correction as stipulated under 8 shall be applied where necessary.

7. PRECISION

7.1 The duplicate results shall not differ by more than the following:

	<i>Repeatability</i>	<i>Reproducibility</i>
Up to 230°C	1.6 g	3.5 g
Up to 230 to 315°C	1.5 g	3.4 g
Total distillate	1.7 g	1.7 g

8. BAROMETRIC PRESSURE CORRECTION

8.1 If the barometric pressure during the period of test remains within the range of 760 ± 5 mm, no correction need be applied to the specified distillation temperatures. If the pressure is beyond that range, apply the following correction to the specified temperatures:

$$\text{Correction for temperature in degrees centigrade} = 0.00012 (760 - P)(t + 273)$$

where

P = corrected barometric pressure during test, and

t = specified temperature in degrees centigrade.

As in the Original Standard, this Page is Intentionally Left Blank

IS : 1214 - 1978

Indian Standard

METHODS FOR TESTING
TAR AND BITUMINOUS MATERIALS:
DETERMINATION OF MATTER
INSOLUBLE IN BENZENE

(First Revision)

This Standard has been deleted Vide Amendment No. 1 |

Indian Standard
**METHODS FOR TESTING
TAR AND BITUMINOUS MATERIALS:
DETERMINATION OF MATTER
INSOLUBLE IN TOLUENE**
(First Revision)

1. SCOPE

1.1 This standard covers the methods for the determination of matter insoluble in toluene for road tar and pitch.

2. METHOD A (FOR SOFT GRADE PITCH)

2.1 Apparatus

2.1.1 *Beaker* — of 200-ml capacity.

2.1.2 *Sintered Glass Crucible* — of porosity No. 4.

2.1.3 *Filter Papers* — two, each about 150 mm in diameter, grade Whatman No. 5 or its equivalent.

2.1.3.1 *Filtering funnel and bottle*

2.1.4 *Water Bath* — maintained to constant temperature of $95 \pm 5^\circ\text{C}$. Glycerine may be used in place of water for temperature 95°C and above.

2.1.5 *A 100-ml Graduated Cylinder*

2.2 Reagent

2.2.1 *Toluene* — nitration grade, conforming to IS : 537-1967*.

2.3 Procedure

2.3.1 Warm in a 200-ml beaker about 2 g of the thoroughly mixed material, accurately weighed, on a water bath, and intimately mix with 100 ml of hot toluene at $95 \pm 5^\circ\text{C}$. After settling for 20 minutes with the beaker standing on the water bath, decant the supernatant liquid cautiously, avoiding disturbance of the sediment, through either (a) the filter papers, or (b) the sintered glass crucible.

*Specification for toluene, pure, nitration grade (*first revision*).

2.3.1.1 Method using filter papers — Counterpoised double filter papers shall be used. For counterpoising, heat the two filter papers to a temperature of $100 \pm 2^\circ\text{C}$ and reduce them to equal weight by removing the apex of the heavier paper after folding. For filtering, use the uncut paper inside the originally heavier paper, so that separated material is retained by the inner paper, yet both of them are equally subjected to any action exerted by toluene. Wash the residue by repeated decantation with toluene heated to $95 \pm 5^\circ\text{C}$ until 300 ml of toluene have been used in all. Transfer the residue to the filter paper and continue the washing until altogether 500 ml of hot toluene have been used. Dry the residue in an oven at a temperature of $100 \pm 2^\circ\text{C}$ until it is of constant weight.

2.3.1.2 Method using sintered glass crucible — Dry the crucible at a temperature of $100 \pm 2^\circ\text{C}$ and weigh accurately when cool. Decant the toluene solution through the crucible using gentle suction to assist filtration and avoiding the transfer of the sediment. Wash repeatedly by decantation until 300 ml of toluene have been used. Transfer the sediment in the beaker to the crucible and continue washing until 500 ml of toluene have in all been used. Dry the residue in an oven at a temperature of $100 \pm 2^\circ\text{C}$ until it is of constant weight.

2.3.2 Preserve the residue in either case with the filter paper or sintered crucible for ash determination (see IS : 1217-1978*).

2.4 Calculation — Calculate and express the result as percentage by mass of the material taken for the test as follows:

$$\text{Insoluble matter in toluene,} \\ \text{percent by mass} = \frac{100 W_2}{W_1}$$

where

W_1 = mass of the dry material in g, and

W_2 = mass of insoluble matter in g.

3. METHOD B (FOR SOFT MEDIUM, HARD MEDIUM AND HARD PITCH GRADES)

3.1 Procedure

3.1.1 Treat about one gram of the material, finely divided, if possible, and accurately weighed, with 100 ml of toluene at the laboratory temperature, in the manner described under 2.3.1.

3.1.2 Treat the residue in the beaker in exactly the same manner as described in 2.3.1 with a further 100 ml of toluene at laboratory

*Methods for testing tar and bituminous materials: Determination of mineral matter (ash) (first revision).

temperature. Then treat it with three successive quantities, each of 100 ml, of toluene at $95 \pm 5^\circ\text{C}$ in exactly the same manner as described in 2.3.1 except that each settling period during which the beaker is standing in the water bath need only be of five minutes.

3.1.3 Transfer the residue to the filter paper or sintered glass crucible and continue the washing until a further 500 ml of hot toluene have been used. Dry the residue in an oven at a temperature of $100 \pm 2^\circ\text{C}$ until it is of constant mass.

3.1.4 Preserve the residue with the filter paper for ash determination (see IS : 1217-1978*).

3.2 Calculation — Calculate and express the result as percentage by mass of the material taken for the test as follows:

$$\begin{array}{l} \text{Insoluble matter in toluene,} \\ \text{percent by mass} \end{array} = \frac{W_1}{W_2} \times 100 \text{ g}$$

where

W_1 = dry mass of the material, and

W_2 = mass of insoluble matter.

4. REPORT

4.1 Report the percentage insoluble in toluene to the nearest 0.1 percent.

5. PRECISION

5.1 The duplicate test results should not differ by more than the following:

Repeatability
0.5 percent

Reproducibility
1.0 percent

6. PRECAUTION

6.1 The solvent toluene is extremely inflammable. Handling of toluene shall be carried out away from any source of heat or flames.

*Methods for testing tar and bituminous materials: Determination of mineral matter (ash) (first revision).

As in the Original Standard, this Page is Intentionally Left Blank

*Indian Standard*METHODS FOR TESTING
TAR AND BITUMINOUS MATERIALS:
DETERMINATION OF SOLUBILITY IN
CARBON DISULPHIDE OR
TRICHLOROETHYLENE*(First Revision)***1. SCOPE**

1.1 This standard covers the methods for the determination of solubility in carbon disulphide or trichloroethylene for asphaltic bitumens and native asphalts.

2. METHOD A (FOR ASPHALTIC BITUMEN)**2.1 Apparatus**

2.1.1 *Gooch Crucible*

2.1.2 *Conical Glass Flask* — of 200-ml capacity.

2.2 Solvent

2.2.1 *Carbon Disulphide* — redistilled grade, conforming to IS: 717-1969*.

2.2.2 *Trichloroethylene* — conforming to IS : 245-1970†.

2.3 Preparation of the Material — If the material contains water, heat it to a temperature not exceeding 130°C until the water has been removed, stirring constantly, when possible, during heating. Perform this operation as expeditiously as possible.

2.4 Preparation of Gooch Crucible — Insert the filter tube in the stopper of the filtering flask, set the Gooch crucible in the filter tube, and connect the flask to the suction pump. Fill the crucible with some of the suspension of asbestos in the water, allow it to settle partly in the crucible and apply a light suction to draw off the water, leaving a firm mat of asbestos in the crucible. Add more suspended asbestos and repeat the process until a mat weighing 0.5 ± 0.1 g is built up after

*Specification for carbon disulphide, technical (*first revision*).

†Specification for trichloroethylene, technical (*second revision*).

IS : 1216 - 1978

drying. Wash the asbestos mat thoroughly with water and dry in the oven at a temperature of 150°C. Cool the crucible in the desiccator, weigh and replace it in the dry filter tube supported in the clean, dry filtering flask.

2.4.1 In the determination, the asbestos apparently absorbs, irreversibly a small amount of soluble bitumen (usually 1 to 5 mg/g of asbestos) which is not removed by a subsequent washing with solvent. The weight of asbestos used, therefore, shall be kept within the specified limits to ensure reproducible results.

2.5 Procedure — Weigh about 2 g of the dry material correct to the nearest 0.001 g into a 200-ml conical flask and add 100 ml of carbon disulphide or trichloroethylene. Stir the contents of the flask, and then allow it to stand, loosely corked, for a period of one hour. Filter the contents of the flask through the Gooch crucible prepared as described under 2.4 which has been weighed to the nearest 0.001 g. Moisten the asbestos pad with carbon disulphide before commencing filtration, and filter at a rate of not more than two drops per second at first. The filtrate shall be quite clear. Transfer the insoluble matter remaining in the flask to the crucible by washing out the flask with a stream of carbon disulphide or trichloroethylene from a wash bottle. Wash the material retained in the crucible with successive small amounts of carbon disulphide or trichloroethylene until a filtrate is obtained which is not discoloured. Allow the crucible to dry in air for 30 minutes, after which place it in an oven at 100 to 110°C for one hour. Allow the crucible to cool in a desiccator and then weigh.

2.6 Calculation and Report — Calculate the matter soluble in carbon disulphide or trichloroethylene as follows:

$$\begin{array}{l} \text{Matter soluble in carbon disulphide} \\ \text{or trichloroethylene, percent} \end{array} = \frac{(W_1 - W_2)}{W_1} \times 100$$

where

W_1 = weight in g of dry sample taken for the test, and

W_2 = weight in g of insoluble material retained in the Gooch crucible.

2.6.1 Report the result obtained in 2.6 to the nearest 0.05 percent as the matter soluble in carbon disulphide or trichloroethylene of the dry material.

2.7 Precision — Test results shall not differ from the mean by more than the following:

<i>Matter Soluble in Carbon Disulphide or Trichloroethylene</i>	<i>Repeatability</i>	<i>Reproducibility</i>
Below 98 percent	0.5	1.0
98 to 100 percent	0.1	0.2

3. METHOD B (FOR NATIVE ASPHALTS)

3.1 Apparatus

3.1.1 Glass Tap Funnel — approximately 100 mm in diameter, the stem fitted with a tap and the top ground flat

3.1.2 Glass Plate — to cover the funnel, about 120 mm in diameter, with a hole of about 16 mm diameter in the centre.

3.1.3 Glass Funnel — smaller than that described under 3.1.1, with its stem passing through a cork placed in the hole in the glass plate, the lower end of the stem reaching approximately half-way down the tap funnel.

3.1.4 Filter Papers — two, Whatman No. 5 or equivalent filter papers, 185 mm in diameter, dried in a suitable oven, cooled in a desiccator, counterpoised and folded together as shown in Fig. 1.

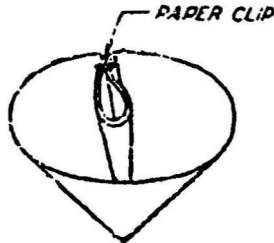

FIG. 1 FOLDED FILTER PAPER

3.2 Solvent and Material

3.2.1 Carbon Disulphide — redistilled, conforming to IS : 717-1969*.

3.2.2 Cement — suitable for sealing the glass plate to the funnel. It may be prepared with 10 g of gelatin, 80 ml of water and 20 g of glycerine.

*Specification for carbon disulphide, technical (first revision).

3.3 Preparation of Sample — If the sample contains water, heat a 100 g portion at a temperature not exceeding 130°C, the material being constantly stirred when possible, until the rate of loss in weight of the sample does not exceed 0.1 g during a 15-minute period of heating.

3.3.1 If the loss in weight on drying exceeds 0.1 percent, determine the water content of another sample of the material in accordance with IS : 1211-1978*.

3.4 Procedure — Dry the two filter papers (see 3.1.4) in an oven at 100 to 110°C, cool in a desiccator, counterpoise, fold together as illustrated in Fig. 1 and place in the tap funnel. Weigh about 2 g of the dry material, as prepared in 2.3, correct to the nearest 0.001 g in the filter papers and secure the cover to the funnel by means of the cement. Now add carbon disulphide or trichloroethylene through the small funnel until the filter paper is about half filled, and then allow it to stand for 30 minutes. Draw the solution off through the tap. Place a watch glass on the small funnel to minimize evaporation. Close the tap and introduce a further quantity of carbon disulphide or trichloroethylene through the small funnel and again draw the solution off after 30 minutes. Repeat this procedure until the solvent drawn off is no longer discoloured. When the filtration is completed, remove the cover and allow the filter papers to dry in air for 30 minutes before placing them in a ventilated air oven at 100 to 110°C for one hour. Next place the filter papers in a desiccator and when cool, weigh the inner filter paper and contents, using the outer filter paper as a counterpoise.

3.5 Calculation — Calculate the solubility of the dry material as follows:

$$\begin{array}{l} \text{Matter soluble in carbon} \\ \text{disulphide or trichloroethylene,} \\ \text{percent by weight} \end{array} = \left(\frac{W_1 - W_2}{W_1} \times 100 \right) \times \frac{100}{100 + W_3}$$

where

W_1 = mass in g of the dry sample taken for the test;

W_2 = mass in g of recovered insoluble matter; and

W_3 = water content of sample, if determined.

3.6 Report — Report the result obtained in 3.5 to the nearest 0.05 percent as the matter soluble in carbon disulphide or trichloroethylene.

3.7 Precision — Test results shall not differ from the mean by more than the following:

Repeatability	0.5
Reproducibility	0.5

*Methods for testing tar and bituminous materials: Determination of water content (Dean and Stark method) (first revision).

3.7.1 These precision figures do not include any allowance for differences due to variations in samples.

4. PRECAUTIONS

4.1 The handling of carbon disulphide shall be carried out away from flames or other sources of heat as the solvent is extremely inflammable and the vapour is liable to ignite spontaneously on contact with a hot surface.

4.2 The vapours of carbon disulphide are toxic and adequate ventilation shall be provided.

As in the Original Standard, this Page is Intentionally Left Blank

*Indian Standard***METHODS FOR TESTING TAR AND
BITUMINOUS MATERIALS: DETERMINATION
OF MINERAL MATTER (ASH)***(First Revision)*

(Incorporating Amendment No. 1)

1. SCOPE

1.1 This standard covers the method for determination of mineral matter (ash) for crude coal tar, pitch and other bituminous products.

2. APPARATUS

2.1 A silica crucible of 30 ml capacity.

3. PROCEDURE

3.1 Thoroughly clean and dry the crucible in an oven. Cool and weigh (*a*). Transfer about 2 g of the thoroughly mixed separated tar into the crucible and weigh (*b*). Heat the crucible gently on a hot plate gradually increasing the heat to remove volatile matter without loss of content due to violent ebullition. Finally, heat the crucible in a muffle furnace at a temperature high enough to complete the incineration. Cool to 100°C and place it in a desiccator and weigh. Repeat cooling and weighing till a constant weight is recorded (*c*). Take 10 g of powdered sample (passing through 600 micron IS sieve) and treat with about 100 ml of toluene at 65 to 70°C for 15 minutes. Filter through filter paper No. 40 (ashless). Wash the residue with hot toluene (65 to 70°C) till filtrate becomes of straw colour. Dry the residue and finally ignite in a muffle furnace at 900 ± 10°C for coal tar products or at 700 ± 10°C for petroleum products till constant mass is obtained.

4. CALCULATION

4.1 Calculate the percentage of ash content on the weight of the tar taken on moisture-free basis as follows:

$$\text{Percentage of ash content} = \frac{c - a}{b - a} \times 100$$

where

a = mass of crucible in g,

b = mass of crucible and moisture free sample in g, and

c = mass of crucible and ash in g.

As in the Original Standard, this Page is Intentionally Left Blank

Indian Standard

**METHODS FOR TESTING
TAR AND BITUMINOUS MATERIALS:
DETERMINATION OF PHENOLS**

(First Revision)

1. SCOPE

1.1 This standard covers the method for the determination of phenols for road tar.

2. EXTRACTION

2.1 The phenols shall be extracted by a solution of sodium hydroxide and the extract shall be boiled to remove neutral oils and bases. The phenols shall then be liberated by the addition of hydrochloric acid conforming to analytical reagent grade of IS : 265-1962* and their volume shall be measured.

3. APPARATUS

3.1 **Phenols Flask** — of glass, conical, with *t* long graduated neck and of the shape, dimensions and tolerances as shown in Fig. 1 and as given below

Capacity	200 ± 10 ml
Maximum permissible error on capacity corresponding to any graduation mark	± 0.1 ml
Maximum permissible difference between the error at any two graduation marks	± 0.1 ml

3.2 A Beaker of Suitable Size**3.3 Separating Funnel Stoppered**

3.4 **Any Suitable Thermometer** — covering a range of 40 to 70°C.

*Specification for hydrochloric acid (*revised*).

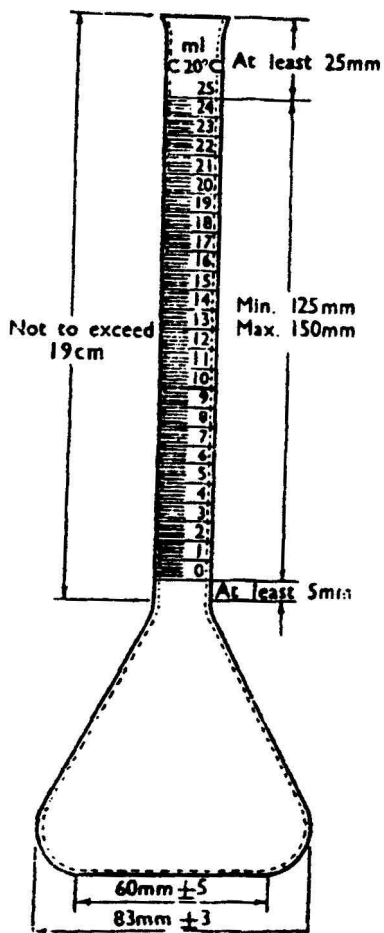

FIG. 1 PHENOLS FLASK

4. REAGENTS

4.1 Sodium Hydroxide Solution — 10 percent *m/m* clear aqueous solution.

4.2 Hydrochloric Acid Concentrated — conforming to analytical reagent grade of IS : 265-1962*.

*Specification for hydrochloric acid (*revised*).

4.3 Sodium Chloride — dry powdered.

4.4 Methyl Orange Indicator — 0.1 g of methyl orange dissolved in 100 ml of warm distilled water.

5. PROCEDURE

5.1 Warm, if necessary, the oil distilling to 270°C in the distillation test (*see* Method B of IS : 1213-1978*), until completely liquid, and transfer the whole of the oil to a stoppered separating funnel of appropriate capacity. Rinse the receivers from which the distillates were transferred with an equal volume of a clear aqueous 10 percent (by mass) solution of sodium hydroxide, previously heated to between 40°C and 70°C, and add to the oil in the separating funnel. Agitate the contents of the funnel vigorously for five minutes, and then allow it to stand.

5.2 After it has settled, run the alkaline layer into a beaker. Agitate the upper layer for five minutes with a further quantity of hot sodium hydroxide solution, equal to one quarter of the volume of the distillate which is being washed, and with further successive quantities of the hot sodium hydroxide solution, each equal in volume to the last, until all the phenols have been removed. During the washing process, keep the contents of the funnel in a liquid condition, immersing the funnel, if necessary in warm water at 40 to 70°C.

5.2.1 The complete removal of phenols can be ascertained by slightly acidifying the last washing with concentrated hydrochloric acid conforming to analytical reagent grade of IS : 265-1962† and examining for separated phenols. A large excess of sodium hydroxide shall be avoided, but some excess should be maintained. As a rough guide, 25 ml of sodium hydroxide solution of the strength indicated may be taken as sufficient to remove about 5 ml of phenols.

5.2.2 Reserve the tar distillate after removal of phenols for the determination of naphthalene (*see* IS : 1219-1978‡).

5.3 Collect the alkali extracts, including any portion acidified, for the purpose of testing. Make sure that the combined washings are alkaline. Boil vigorously for 20 minutes, using fragments of porous or other suitable inert material to prevent bumping. Cool, and if the extract is clear, transfer direct to the phenols flask.

5.3.1 If it be expected that the tar contains $3\frac{1}{2}$ percent or more of phenols, the boiled washings (after filtration through glass wool, if

*Methods for testing tar and bituminous materials : Distillation test (*first revision*).

†Specification for hydrochloric acid (*revised*).

‡Methods for testing tar and bituminous materials : Determination of naphthalene (*first revision*).

IS : 1218 - 1978

necessary) shall be divided about evenly between two phenols flasks, the subsequent specified procedure being carried out on the contents of each flask and the volumes of phenols recovered being totalled.

5.4 If the solution is not clear, filter it through glass wool, previously moistened with saturated aqueous sodium chloride solution; collect the filtrate in the phenols flask, wash the glass wool with 25 ml of saturated sodium chloride solution and add to the filtered soda washings. Add methyl orange indicator solution, followed by concentrated hydrochloric acid until after vigorous shaking together of the two layers, the methyl orange just indicates distinct acidity. During the addition of the hydrochloric acid, cool the contents of the flask by immersing the flask from time to time in cold water.

5.5 Add just sufficient powdered sodium chloride to saturate the aqueous layer, and to leave a few particles undissolved. Bring the phenols into the graduated portion of the flask by adding saturated sodium chloride solution. Allow it to stand, preferably overnight, and then read the volume of phenols.

6. CALCULATION AND REPORT

6.1 Calculate and report the percentage by volume of the phenols in the original sample of tar taken for distillation as under:

$$\text{Percentage phenol} = \frac{a}{b} \times 100$$

where

a = volume of phenol in ml, and

b = volume of original sample of tar taken in ml.

6.1.1 The phenols as determined always contain water which has not been derived from the distillate examined.

6.1.2 When the percentage of phenols is required by mass, assume the density of phenols to be 1.04 g/ml, and calculate accordingly.

**AMENDMENT NO. 2 MAY 2008
TO
IS 1218 : 1978 METHODS FOR TESTING
TAR AND BITUMINOUS MATERIALS:
DETERMINATION OF PHENOLS**

(First Revision)

(Page 133, clause 3.4) — Add 'having a least count of 0.1°C' after '70°C'.

(PCD 6)

Reprography Unit, BIS, New Delhi, India

Indian Standard
METHODS FOR TESTING
TAR AND BITUMINOUS MATERIALS:
DETERMINATION OF NAPHTHALENE
(*First Revision*)

1. SCOPE

1.1 This standard covers the method for the determination of naphthalene in road tar.

1.2 This determination is necessary only in respect of the naphthalene deposited at 15.5°C from solution in the total distillate up to 270°C .

2. PROCESS

2.1 The distillation fraction of tar distilling up to 270°C left after the removal of phenols is cooled to $15.5 \pm 0.5^{\circ}\text{C}$ and the solid separated and weighed.

3. APPARATUS

3.1 **Crystallizing-Point Apparatus** — as described under 5.1.

3.2 **Buchner Funnel and Flask**

3.3 **Hand Screw Press**

3.4 **Thermometer**

3.5 **Blotting Paper**

3.6 **A Filter Pump**

4. PROCEDURE

4.1 Collect the distillate recovered up to 270°C according to Method B of IS : 1213-1978*. This shall be washed free from phenols (see IS : 1218-1978†). Cool the residue to $15.5 \pm 0.5^{\circ}\text{C}$ and maintain it with occasional stirring within these limits of temperature for two hours. Naphthalene crystallizes out.

4.2 Transfer the cooled material to a cold Buchner funnel fitted with a rapid filter proper, and rapidly remove as much oil as possible using a filter pump. Place the crude naphthalene between sheets of blotting paper and press in a hand screw press. Remove the oily margins of the

*Methods for testing tar and bituminous materials: Distillation test (*first revision*).

†Methods for testing and bituminous materials: Determination of phenols (*first revision*).

cake, and again press separately. Conduct the operations, starting with the transfer to the Buchner funnel to the preliminary pressing, with utmost rapidity.

4.3 Weigh the pressed naphthalene and calculate the percentage by weight in the original tar.

4.4 Determine the corrected wet crystallizing-point' of the pressed naphthalene by the method described in 5.

5. CORRECTED WET CRYSTALLIZING-POINT

5.1 **Apparatus** — A crystallizing-point apparatus of the shape, dimensions and tolerances given in Fig. 1, consisting of the following.

5.1.1 *Outer Glass Test Tube* — which serves as an air jacket, shall be weighed with lead shots or similar loading material. It is provided with a cork through which the inner tube, as described in 5.1.2, is held in position.

5.1.2 *Inner Glass Test Tube* — approximately 25 mm in diameter, closed by means of a cork which carries a stirrer in the form of a loop of glass with a glass stem and a standard thermometer (see 5.1.4) placed centrally within the tube and the glass loop and the bottom of the bulb being about 10 mm from the bottom of the inner tube. The cork is so fixed that the immersion mark on the thermometer is level with the top of the cork.

5.1.3 *Cooling Bath* — a glass beaker of 1 000 ml capacity and 150 mm in height with the level of the liquid at least as high as the level of the sample in the inner tube.

5.1.4 *Thermometer* — with the following dimensions and characteristics:

Range	65 to 90°C
Graduation at each	0.1°C
Longer lines at each	0.5°C and 1.0°C
Fully figured at each	2°C
Immersion	100 mm
Maximum overall length	400 mm
Maximum length of main scale	215 mm
Maximum bulb length	12 mm
Maximum distance from bottom of bulb to top of contraction chamber	25 mm
Limit of accuracy	0.05°C

5.2 **Material for Test** — While the difference between the crystallizing-point of dry naphthalene and of naphthalene containing a small amount of water is appreciable, the lowering of the crystallizing-point ceases when a minimum of two percent of water is present. Therefore, if the samples should contain two percent or more of water, it shall be

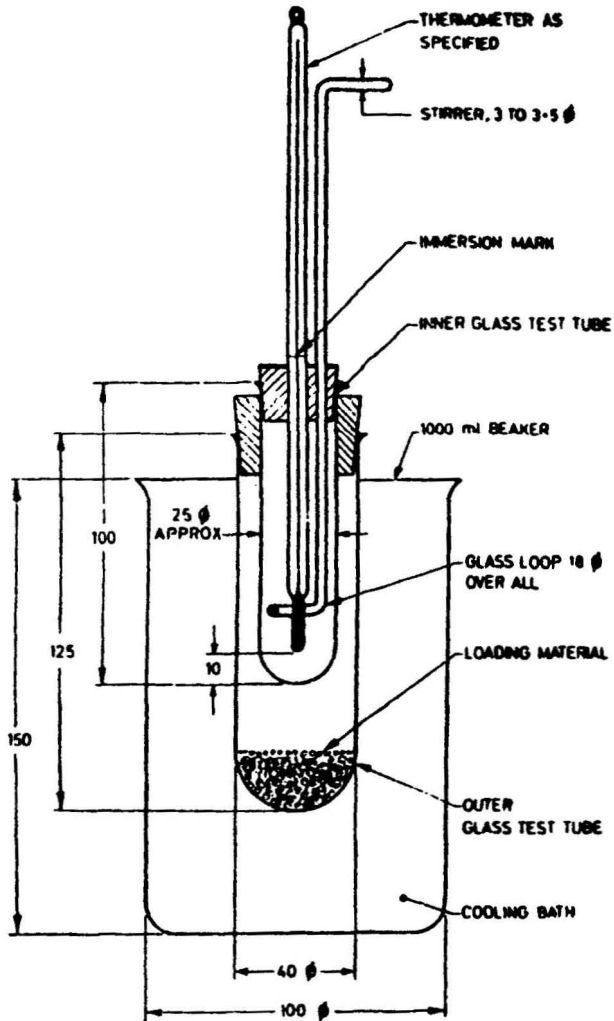

± 5 percent tolerance on dimensions except where otherwise stated. All diameter dimensions are external.

All dimensions in millimetres.

FIG. 1 CRYSTALLIZING-POINT — ASSEMBLY OF APPARATUS

IS : 1219 - 1978

examined as received. If the sample should contain a smaller percentage of water, 0.5 ml of water shall be placed in the inner tube of the crystallizing-point apparatus before the sample is introduced as described under 5.3. If the test is carried out in the presence of two percent or more of water, the addition of 0.85°C to the observed crystallizing-point gives the crystallizing-point of the material on the dry basis.

5.3 Procedure — Place about 40 g of the material for test in a loosely stoppered conical flask which has been warmed in a boiling water bath to 85°C. Mix the contents thoroughly and pour about 20 g into the warmed inner tube of the crystallizing-point apparatus. Place the tube in its jacket and assemble the apparatus as shown in Fig. 1 with the bath 6 to 8°C below the expected crystallizing-point. Do not heat the water during the subsequent operations. Take the bath thermometer readings at intervals of half a minute, starting when the temperature has fallen to 81°C. Stir the contents of the inner tube continuously.

5.4 Results

5.4.1 The crystallizing-point corresponds to the first five consecutive readings during which the temperature remains constant within 0.05°C. Supercooling may occur, in which case the five readings may be observed after the temperature rise. A temperature rise of 1°C shall be regarded as the maximum allowable.

5.4.2 If a constant temperature within 0.05°C is not obtained over five readings, take six final readings commencing with the first of two successive readings within 0.05°C. Plot the readings on graph paper against time intervals, and draw a straight line to fit evenly between the first and second, and between the fifth and the sixth of the six points just mentioned. Produce the line backwards until it intersects the earlier portion of the curve.

5.5 Report

5.5.1 Report the constant temperature within 0.05°C (see 5.4.1) or the point of intersection as found in 5.4.2, as the crystallizing-point.

5.5.2 Report as corrected wet crystallizing-point the value obtained after adding 0.85°C to the observed crystallizing-point.

5.5.3 The corrected wet crystallizing-point shall be not lower than 70°C. If it is found to be below 70°C, the indication is that the removal of the excessive oil as prescribed in 4.2 has not been carried out satisfactorily and the determination has to be repeated.

6. PRECISION

6.1 The duplicate results shall not differ by more than the following:

Repeatability	0.1°C
Reproducibility	0.8°C

Indian Standard

**METHODS FOR TESTING
TAR AND BITUMINOUS MATERIALS:
DETERMINATION OF VOLATILE
MATTER CONTENT**

(First Revision)

1. SCOPE

1.1 This standard covers the method for the determination of volatile matter content of coal tar pitch.

2. APPARATUS

2.1 **Platinum Crucible** — complying with the following requirements (see Fig. 1):

External diameter at base	24.0 ± 0.5 mm
External diameter at top	34.0 ± 0.25 mm
External height	35.0 ± 0.5 mm
Volume to brim	27.0 ± 0.5 ml
Weight	22.0 ± 1.0 g

2.1.1 The crucible shall be provided with a closely fitting lid, grooved to receive the rim of the crucible and having a central hole 2 mm in diameter, as shown in Fig. 1.

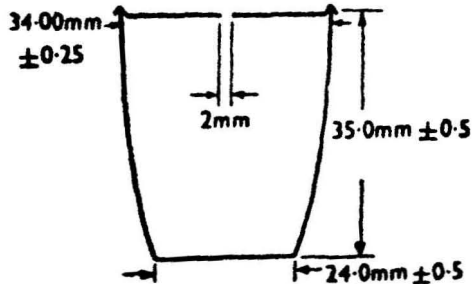

FIG. 1 PLATINUM CRUCIBLE AND LID

IS : 1220 - 1978

2.2 Meker Burner — having a diameter of 31 mm at the top, the flame diameter being 30 mm maximum.

2.3 Water Manometer — connected by means of a T-piece with the gas supply entering the burner.

2.4 Three-Arm Crucible Support — with silica points (see Fig. 2).

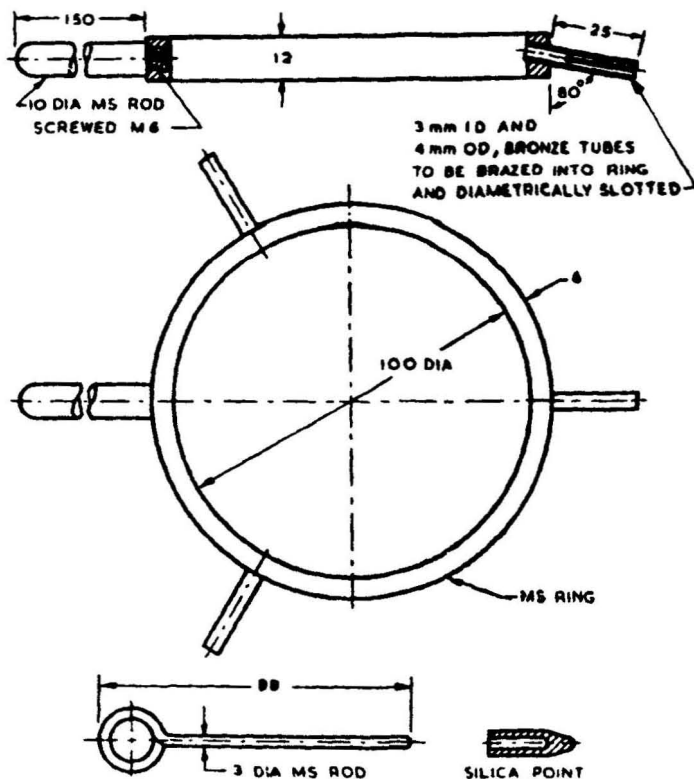

FIG. 2 THREE-ARM CRUCIBLE SUPPORT WITH SILICA POINTS

2.5 Retort Stand and Clamp — to hold the three-arm crucible support (see Fig. 3), so arranged that when in position, the bottom of the crucible is 10 mm above the burner, the crucible being completely enveloped by the flames.

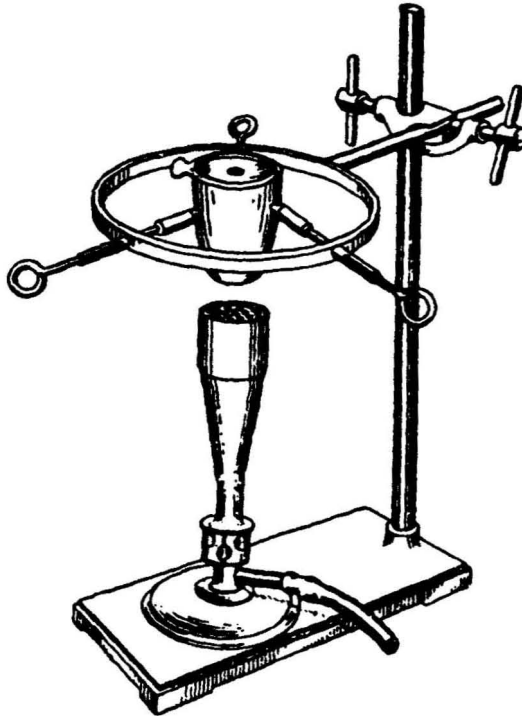

FIG. 3 ASSEMBLY OF APPARATUS

2.6 Standard Draught Screen — consisting of a semi-cylindrical metal sheet, 300 mm in diameter and sufficiently high for the purpose.

3. REAGENT

3.1 Potassium Chromate — pure powdered potassium chromate.

4. PROCEDURE

4.1 Assemble the apparatus as illustrated in Fig. 3 with the silica points holding the crucible as near the rim as practicable. Spread a small quantity of powdered pure potassium chromate over the bottom of the crucible. Light the burner, taking care that the gas is lit with the flame fully aerated. Slowly increase the gas pressure at the burner until incipient fusion of the potassium chromate is apparent. The final

IS : 1220 - 1978

manometer reading shall be noted as corresponding to the gas pressure to be used in the test on the pitch. The lid of the crucible shall not be used during the trials.

4.2 Clean the crucible, dry and weigh without the lid. Weigh into the crucible 1 g of the finely divided sample and place in position as before with the lid. Relight the burner and, if necessary, readjust the gas pressure until the manometer reading is the same as that noted in the preliminary trial. Place the burner in position under the crucible and, after three minutes, during which the manometer reading shall be kept constant, extinguish the flame. Cool the crucible and weigh without the lid. The loss in mass shall be the volatile matter in the amount of sample taken for the test. Calculate the percentage of volatile matter by mass in the total sample taken for the test.

4.3 If the method has been properly performed, any deposit on the lid at the end of the experiment will be due to decomposition of the volatile matter. If there be any evidence that molten pitch has spurted on to the lid, the test shall be discarded and a fresh determination made.

5. PRECISION

5.1 The duplicate results shall not differ by more than the following:

Repeatability	0.9
Reproducibility	3.8

APPENDIX A

(Clause 0.5)

APPARATUS SCHEDULES

<i>Apparatus</i>	<i>Purpose</i>
Water bath:	
a) Constant temperature	General
b) For temperatures between 5°C and 100°C	do
Hot plate	do
Stop watch or clock or any other timing device	do
Analytical balance, sensitiveness up to 0.1 mg	do
Oven, up to 180°C	do
Specific gravity bottles:	
a) Ordinary, 6 mm dia neck, 50 ml capacity	Determination of specific gravity
b) Wide mouthed, 25 mm dia neck, 50 ml capacity	do
Container dish:	
a) 35 mm deep, 55 mm dia	Determination of penetration and loss on heating
b) 45 mm deep, 70 mm dia	Determination of penetration
Transfer dish	do
Standard needle	Determination of penetration and residue of specified penetration
Penetration apparatus	do
Container dish, 45 mm deep, 70 mm dia	Determination of residue of specified penetration
Ring and ball apparatus	Determination of softening point
Mechanical stirrer	do

IS : 1201 - 1978

to

IS : 1220 - 1978

<i>Apparatus</i>	<i>Purpose</i>
Viscometer fitted with 10-mm and 4-mm cups and other accessories	Determination of viscosity and EVT
Cannon Manning Vacuum Capillary Viscometer	Determination of absolute viscosity
or	
Asphalt Institute Vacuum Capillary Viscometer	
or	
Modified Koppers Vacuum Capillary Viscometer	
Vacuum System HIVAC Pump	do
Cannon-Fenske viscometer for opaque and transparent liquids	Determination of kinematic viscosity
BS-U-Tube modified reverse flow viscometer for opaque liquids	do
Ductility moulds	Ductility test
Testing machine	Ductility test
Pensky-Martens (closed and open) tester	Determination of flash and fire point
Float cup and its assemblies	Float test
Flask, 500 ml capacity	Determination of water content
Condenser	do
Receivers:	
a) 2 ml capacity	do
b) 10 ml capacity	do
c) 25 ml capacity	do
100 ml graduated cylinder	Determination of water content and mineral matter
Distillation flasks:	
a) 150 ml capacity	Distillation test
b) 500 ml capacity	do
c) 750 ml capacity	do
Water condenser	do
Adapter	do

<i>Apparatus</i>	<i>Purpose</i>
Shield	Distillation test
Crow receivers:	
a) 25 ml capacity	do
b) 50 ml capacity	do
c) 100 ml capacity	do
Residue metal containers	do
Draught screen	do
Beaker, 200 ml capacity	Determination of matter insoluble in toluene
Sintered glass crucible	do
Filter paper, filtering funnel and bottle	do
Gooch crucible	do
Flask, 200 ml capacity	do
Glass plate	Solubility in carbon disulphide or trichloroethylene
Glass tap funnel	do
Glass funnel	do
Filter paper	do
Air condenser	Determination of mineral matter and distillation test
Phenols flask	Determination of phenols
Crystallizing-point apparatus	Determination of naphthalene
Buchner funnel and flask	do
Hand screw press	do
Blotting paper	do
Platinum crucible	Determination of volatile matter content
Meker burner	do
Water manometer	do
Three-arm crucible support, retort stand and clamp	do
Draught screen	do

IS : 1201 - 1978

to

IS : 1220 - 1978

Thermometers:

<i>Method of Test</i>	<i>STPTC Designation</i>	<i>IP Designation</i>	<i>ASTM Designation</i>	<i>Nearest IS Designation</i>
a) Determination of specific gravity, penetration	—	IP 8C	—	SM TI/PI-3 of IS : 2480-1973*
b) Determination of residue of specified penetration	—	—	ASTM 11C-62	SM TI/PI-16 or 17 of IS : 2480-1973*
c) Determination of softening point:				
1) Low range and float test	—	—	ASTM 15C-62	SM TI/PI-4 of IS : 2480-1973*
2) High range	—	—	ASTM 16C-62	SM TI/PI-6 of IS : 2480-1973*
d) Determination of viscosity:				
1) Low range	—	IP 8C	—	SM TI/PI-3 of IS : 2480-1973*
2) Medium range	—	IP 9C	—	SM TI/PI-4 of IS : 2480-1973*
3) High range	—	IP 10C	—	SM TI/PI-6 of IS : 2480-1973*
e) Determination of flash point and fire point:				
1) Low range	—	IP 15C	—	SM TI/PI-4 of IS : 2480-1973*
2) High range	—	IP 16C	—	SM TI/PI-16 or 17 of IS : 2480-1973*
f) Determination of loss on heating	—	—	ASTM 13C-62	SM TI/PI-8 of IS : 2480-1973*
g) Distillation test	—	IP 6C	—	SM TI/PI-16 or 17 of IS : 2480-1973*
h) Determination of naphthalene	T 7C	—	—	SM TI/PI-23 of IS : 4825-1968†
j) Determination of ductility	—	IP 8C	—	SM TI/PI-3 of IS : 2480-1973*

*Specification for solid stem general purposes glass thermometers (*first revision*).

†Specification for laboratory and reference thermometers.

Bureau of Indian Standards

BIS is a statutory institution established under the *Bureau of Indian Standards Act, 1986* to promote harmonious development of the activities of standardization, marking and quality certification of goods and attending to connected matters in the country.

Copyright

BIS has the copyright of all its publications. No part of these publications may be reproduced in any form without the prior permission in writing of BIS. This does not preclude the free use, in the course of implementing the standard, of necessary details, such as symbols and sizes, type or grade designations. Enquiries relating to copyright be addressed to the Director (Publications), BIS.

Review of Indian Standards

Amendments are issued to standards as the need arises on the basis of comments. Standards are also reviewed periodically; a standard along with amendments is reaffirmed when such review indicates that no changes are needed; if the review indicates that changes are needed, it is taken up for revision. Users of Indian Standards should ascertain that they are in possession of the latest amendments or edition by referring to the latest issue of 'BIS Catalogue' and 'Standards : Monthly Additions'.

This Indian Standard has been developed by Technical Committee : BCDC 2 and amended by PCD 6

Amendments Issued Since Publication

IS No.	Parts	Amend No.	Date of Issue
1201 to 1220		Amd. No. 1	November 1996
1202		Amd. No. 1	April 1989
1202		Amd. No. 2	October 2004
1203		Amd. No. 1	July 1989
1203		Amd. No. 2	March 1989
1206	Part I	Amd. No. 1	October 2004
1206	Part II	Amd. No. 1	December 2004
1206	Part II	Amd. No. 2	December 2004
1206	Part III	Amd. No. 1	May 2005
1208		Amd. No. 1	October 2004
1217		Amd. No. 1	July 1991

BUREAU OF INDIAN STANDARDS

Headquarters:

Manak Bhavan, 9 Bahadur Shah Zafar Marg, New Delhi 110002.
Telephones: 323 01 31, 323 33 75, 323 94 02

Telegrams: Manaksanstha
(Common to all offices)

Regional Offices:

	Telephone
Central : Manak Bhavan, 9 Bahadur Shah Zafar Marg NEW DELHI 110002	{ 323 76 17 323 38 41
Eastern : 1/14 C. I. T. Scheme VII M, V. I. P. Road, Kankurgachi KOLKATA 700054	{ 337 84 99, 337 85 61 337 86 26, 337 91 20
Northern : SCO 335-336, Sector 34-A, CHANDIGARH 160022	{ 60 38 43 60 20 25
Southern : C. I. T. Campus, IV Cross Road, CHENNAI 600113	{ 235 02 16, 235 04 42 235 15 19, 235 23 15
Western : Manakalaya, E9 MIDC, Marol, Andheri (East) MUMBAI 400093	{ 832 92 95, 832 78 58 832 78 91, 832 78 92

Branches : AHMEDABAD. BANGALORE. BHOPAL. BHUBANESHWAR. COIMBATORE.
FARIDABAD. GHAZIABAD. GUWAHATI. HYDERABAD. JAIPUR. KANPUR. LUCKNOW.
NAGPUR. NALAGARH. PATNA. PUNE. RAJKOT. THIRUVANANTHAPURAM.
VISHAKHAPATNAM